

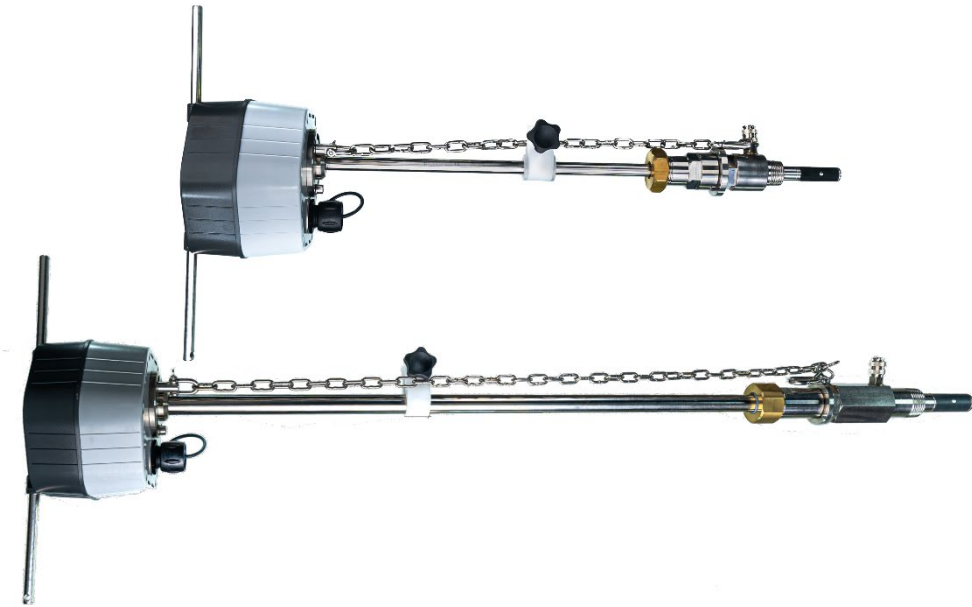

Type 804 - Insertion Flowmeter Technical Manual



080402-3-00X-YYY Type 804, Insertion Flowmeter
080403-3-001-YYY Type 804 mini, Insertion Flowmeter

This document was prepared by the staff of Valeport Ltd., the Company and is the property of the Company, which also owns the copyright therein. All rights conferred by the law of copyright and by virtue of international copyright conventions are reserved to the Company. This document must not be copied, reprinted or reproduced in any material form, either wholly or in part, and the contents of this document and any method or technique available therefrom, must not be disclosed to any other person whatsoever without the prior written consent of the Company.

Document ID MANUAL-1051152335-2 | issue 2.8
Date: March 2024

Valeport Water Ltd,
St. Peter's Quay
TOTNES
Devon, TQ9 5EW
U.K.

Tel: (+44 (0)1803 869292
email: sales@valeportwater.co.uk
web: www.valeportwater.co.uk

As part of our policy of continuous development, we reserve the right to alter, without prior notice, all specifications, designs, prices and conditions of supply for all our equipment

Contents

1	Introduction	3
2	Mechanical Dimensions.....	3
3	Performance.....	4
3.1	Noise / Power.....	4
3.2	Temperature	4
4	Type 804 Setup and Signals.....	5
4.1	COMs to the Type 804	5
4.2	Hardware Connections.....	6
4.2.1	Standard Type 804.....	6
4.2.2	Type 804 External Power	6
4.2.3	RS232 \ RS485 Selection	6
4.2.4	Earthing.....	7
5	Bootloading New Firmware.....	9
6	Output Format Serial COMs	10
6.1	Non - Output Parameters.....	16
6.2	Alarm Output	16
6.3	Supported Units	17
7	Insertion and Profile Factors	18
7.1	When Using Centre Line Method [sensor positioned in the centre of pipe].....	18
7.2	When Using Mean Axial Method [sensor positioned at 1/8 th or 7/8 th of Pipe Diameter].....	19
7.3	Setting the Insertion and Profile Factors	19
8	Pulse Outputs.....	20
8.1	Pulse Output - Flow.....	21
8.2	Pulse Divisor	23
8.3	Temperature	23
8.4	Dosing.....	24
9	Measurement	26
10	Filtering	27
10.1	Moving Average	27
10.2	Exponential.....	27
10.3	Step Change.....	27
11	Battery Measurements.....	28
12	Totalisers	29
13	Temperature	30
14	Modbus RTU Description	31
14.1	Delimiting.....	31
14.2	Format and Byte Size	31
14.2.1	Slave Address (ID).....	32
14.2.2	Function Code.....	32
14.2.3	Data	32
14.2.4	Error Checksum.....	32
14.3	Modbus Commands to the Type 804	32
14.3.1	Modbus Command Structure	32
14.3.2	Functions	33
14.4	Modbus Exception Responses	35
14.4.1	Typical Exception Response	35
14.5	Sleep Mode - Quick Wake/Low Power.....	36
Appendix A	# Command and Modbus Register	37
Appendix B	Flow Computations.....	48
Appendix C	Declaration of Conformity UK and EU	51

1 Introduction

This technical document describes the Type 804 Insertion Flowmeter and its advanced operation. It includes the definition of the output string. Nearly every output is optional and dependant on the settings in the instrument.

The model 804 has the following reference number definition:

- 080402-3-00X-YYY Type 804, Insertion Flowmeter
- 080403-3-001-YYY Type 804 mini, Insertion Flowmeter
 - X = insertion length (1 = 300mm | 2 = 500mm | 3 = 700mm | 4 = 1000mm)
 - YYY = fitting size: BSP or NPT

2 Mechanical Dimensions

	Key	mini	300	500	700	1000
Sensor Diameter		16mm	21mm	21mm	21mm	21mm
Fitting		¾”BSP	1”BSP	1”BSP	1”BSP	1”BSP
Overall Length	L	609mm	798mm	978mm	1218mm	1518mm
Stem Length	A*	476mm	660mm	840mm	1080mm	1380mm
Gland Length	B	149mm	215mm	215mm	215mm	215mm
Valve Length	C**	120mm	120mm	120mm	120mm	120mm
Max Insertable Length	A-(B+C+10)***	197mm	315mm	495mm	735mm	1035mm
Required Clearance	L+C	729mm	918mm	1098mm	1338mm	1638mm

- * to mid-point of sensor – nominal measurement point
- ** example only – to be verified on site
- *** assumed wall thickness of 10mm – to be verified on site

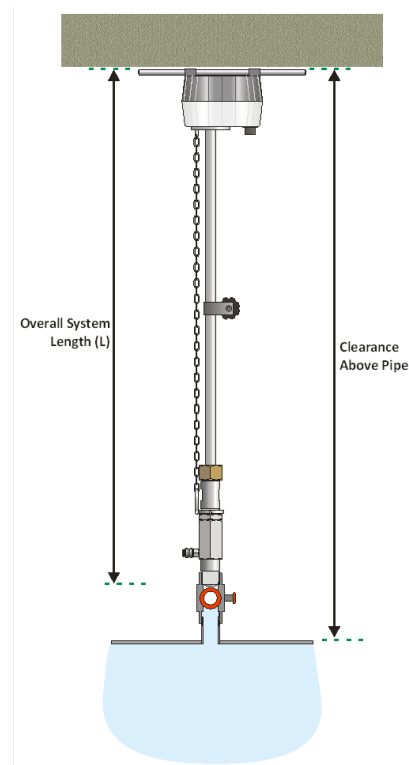
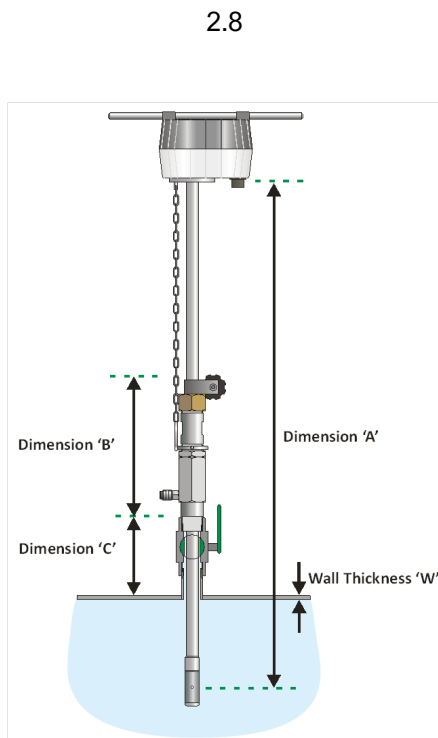

3 Performance

3.1 Noise / Power

See the chart below for a summary of Noise vs Power

Hydrins 2.1 Noise / Power curve

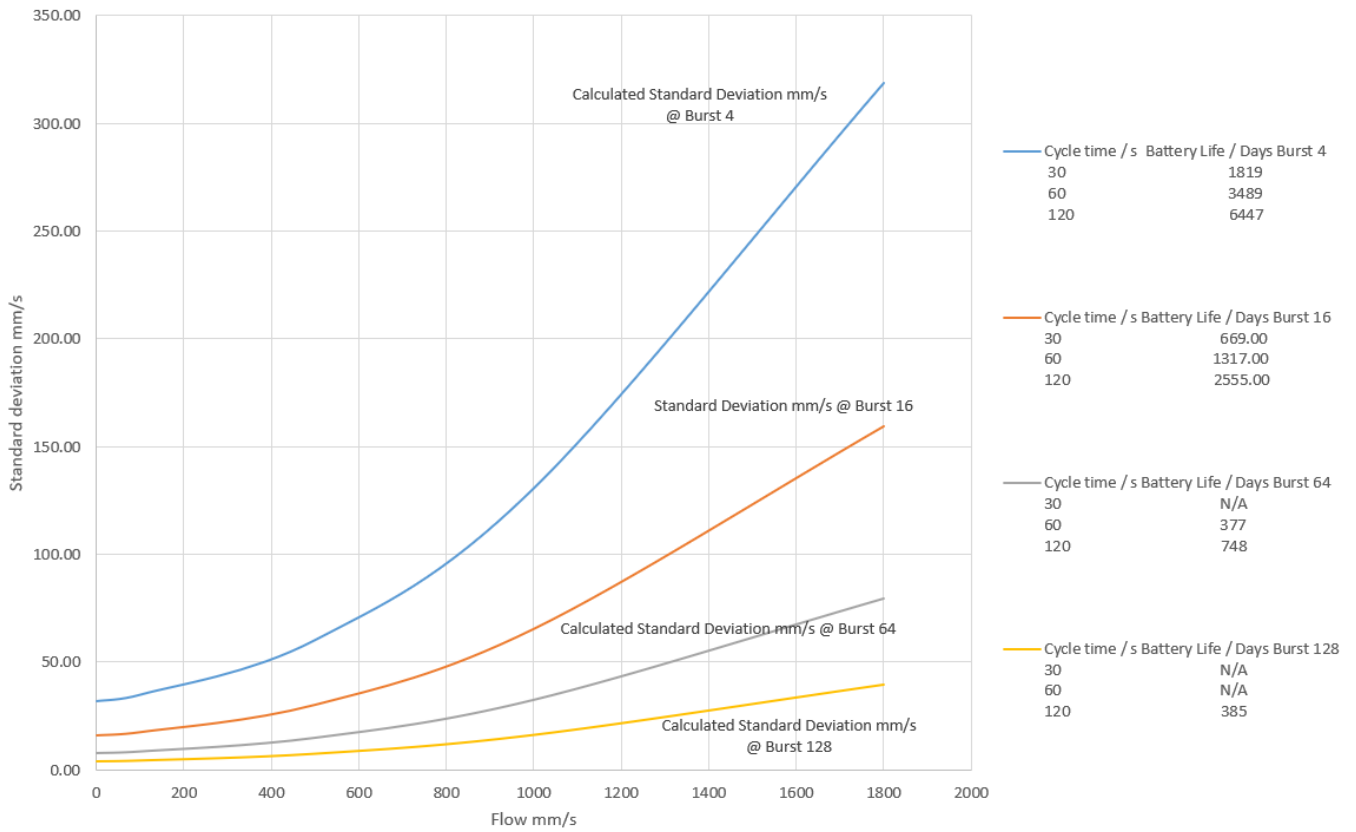

3.2 Temperature

Accuracy: ±0.5°C

Resolution: 12Bit

4 Type 804 Setup and Signals

4.1 COMs to the Type 804

Proprietary: RS232 or RS485

Baud rate is user selectable using the Configure App from 4800 to 38400 (19200 default).

Parity: NONE

Stop bits: 1

On loading the Configure App – available from <http://valeport.download> you are presented with an interface page, this must be set up identically to the instrument:

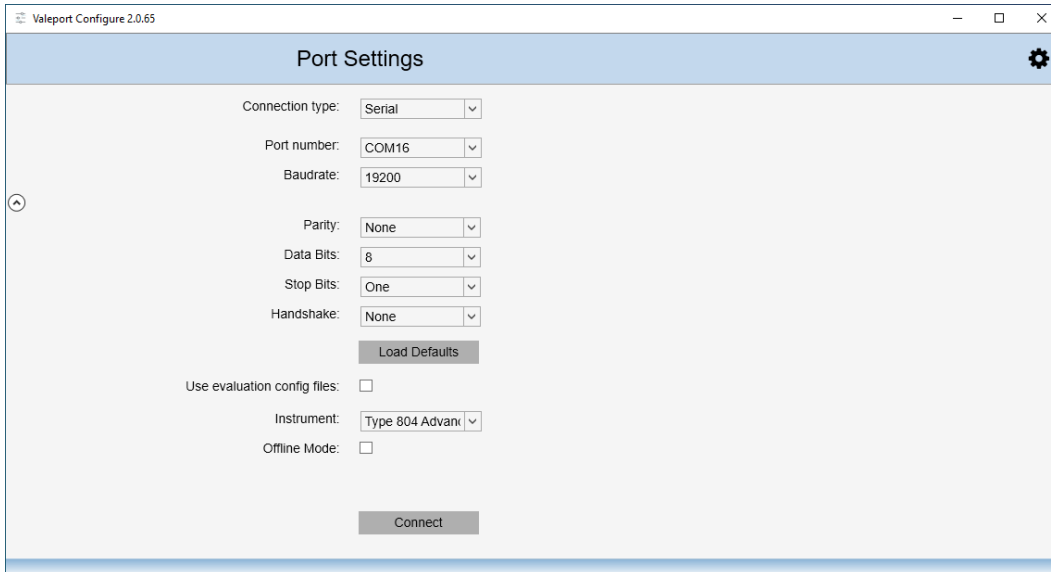

The baud rate can be changed within Configure:

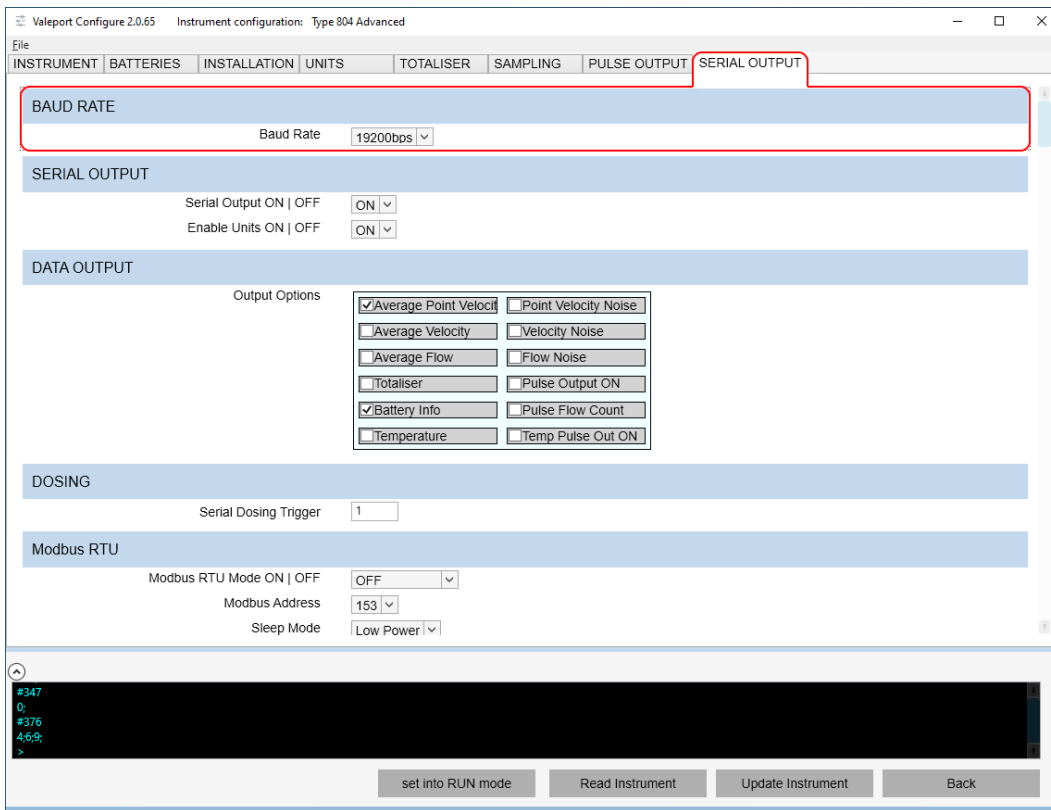

There is the option to use Modbus RTU over RS232 and RS485.

4.2 Hardware Connections

4.2.1 Standard Type 804

The connection to the instrument should be wired up as follows.

10 Way Connector - Female	
Pin	Function
C	Power Ground
D	+3.6 VDC
A	Frequency Out Ground
H	Pulse Output 2
B	Pulse Output 1
J	RS 232 RXD / RS485B (+'ve)
K	RS 232 TXD / RS485A (-'ve)
F	RS232 / RS485 Ground
G	Battery Switch
E	Link to Pin G to power unit

4.2.2 Type 804 External Power

The connection to the instrument should be wired up as follows.

10 Way Connector - Male	
Pin	Function
C	Power Ground
D	12 - 28 VDC
A	Frequency Out Ground
H	Pulse Output 2
B	Pulse Output 1
J	RS 232 RXD / RS485B (+'ve)
K	RS 232 TXD / RS485A (-'ve)
F	RS232 / RS485 Ground
G	Battery Switch
E	Link to Pin G to power unit

4.2.3 RS232 \ RS485 Selection

To change from RS232 to RS485 and vice versa, a hardware connection inside the electronics housing needs to be swapped from one socket to another. This is normally a factory setting but a competent operator can perform the procedure – contact Valeport Water for further information.

4.2.4 Earthing

Each installation is unique and with variations in pipe size, material, lining, corrosion prevention systems and general electrical noise all sites are specific to themselves. If noisy signals are experienced there are a number of things to try before contacting your service provider.

The stem provides the ground connection to the water in the pipe which is critical to the flowmeter's operation. For best results the Type 804 should be isolated from the pipe. There is an isolation layer in the gate valve attachment mechanism.

Do not connect the screen at the customer end of the data cable; this is because the screen is connected to the stem internally. By correctly configuring the cable a difference in DC potential between the two ends of the cable will be prevented.

Any external power provided, whether it be regulated 3.6 V DC for the standard unit or 12 to 28 V DC for the ExP variant the supply must be 'clean'.

If you are experiencing noisy 'data':

1. Insure there is sufficient stem in the water. If you are operating at $\frac{1}{8}$ depth try $\frac{1}{2}$, be sure to change your insertion and profile factors accordingly.
2. Check your mains frequency filter

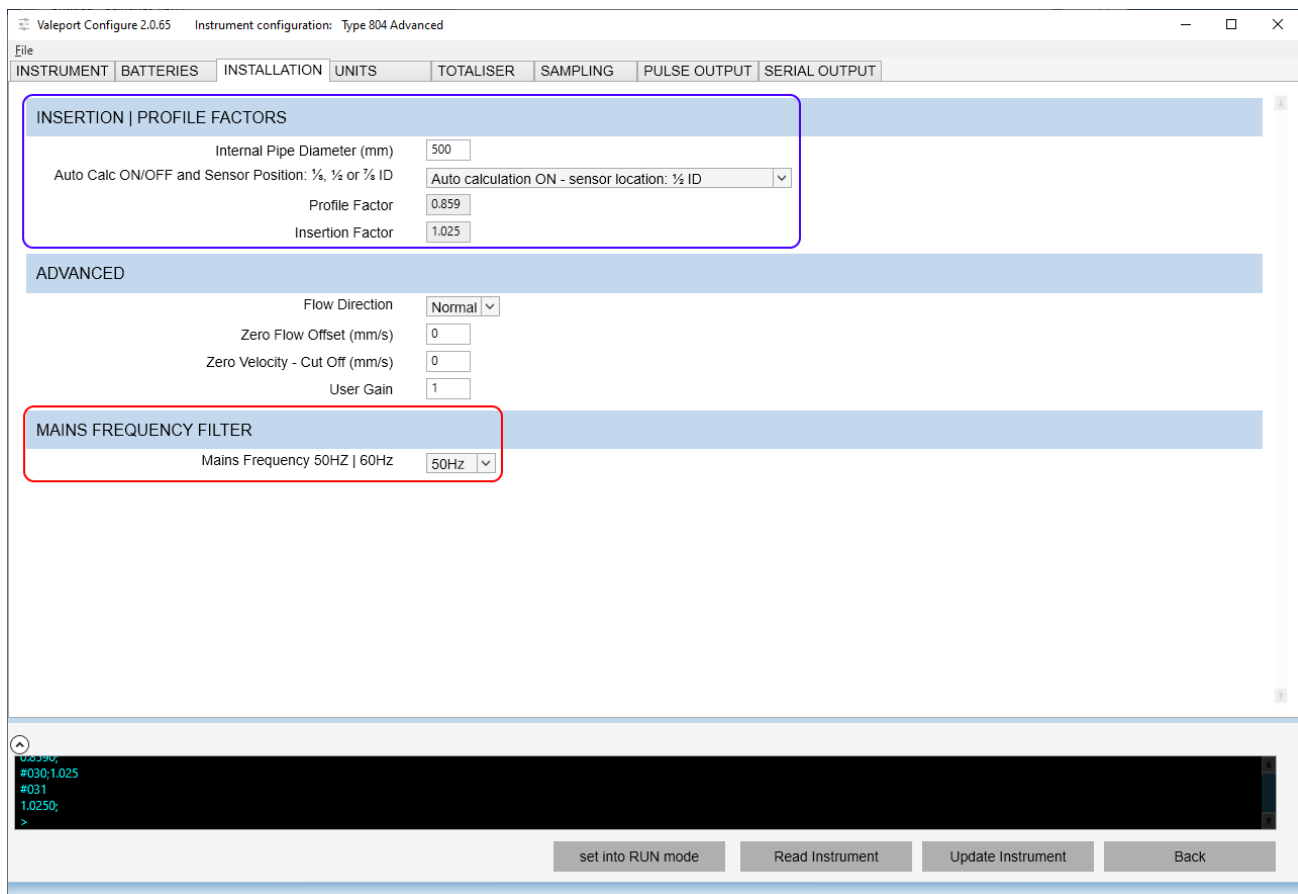

Valeport Configure 2.0.65 Instrument configuration: Type 804 Advanced

File INSTRUMENT BATTERIES INSTALLATION UNITS TOTALISER SAMPLING PULSE OUTPUT SERIAL OUTPUT

INSERTION | PROFILE FACTORS

Internal Pipe Diameter (mm) 500

Auto Calc ON/OFF and Sensor Position: $\frac{1}{4}$, $\frac{1}{2}$ or $\frac{3}{4}$ ID Auto calculation ON - sensor location: $\frac{1}{2}$ ID

Profile Factor 0.859

Insertion Factor 1.025

ADVANCED

Flow Direction Normal

Zero Flow Offset (mm/s) 0

Zero Velocity - Cut Off (mm/s) 0

User Gain 1

MAINS FREQUENCY FILTER

Mains Frequency 50HZ | 60Hz 50Hz

```

0.0330,
#030;1.025
#031
1.0250;
>

```

set into RUN mode Read Instrument Update Instrument Back

If the pipe is lined check for a DC potential difference between the water and the pipe. The pipe should be earthed to the same potential as the water.

In some situations, bonding the spar to the pipe may help.

4.2.4.1 Operating in RS485 COMs Mode

The RS485 standard specifies the maximum voltage applied to the Driver output / Receiver input common mode voltage range is -7 / +12V.

The RS485 transceiver used in the Type 804 is designed for a low power battery system and, therefore, is limited to -7 / +10V. Most drivers are no more than 5V but please ensure the -7 / +10V limits are not exceeded.

Ensure that an RS485 ground connection is made to the Type 804 unit so as to ensure the RS485 signal is kept within the common mode limits

Signals can drift off to high voltage levels if there are high static conditions or cables running parallel to the pipe. This same drift can be generated by static or leakage voltages from a laptop PC mains supply connected to the Type 804.

If such volatile conditions exist it is also recommended to use a terminating resistor at the 'customer end' of the data cable to prevent the RS485+ input from floating.

4.2.4.2 Operating in RS232 COMs Mode

The HydrINS is fitted with a low power Isolated RS232 connection. It is recommended to use a transceiver fitted with internal charge pump to ensure good communication signals.



It is also recommended that the RS-232 Ground is connected to the comms ground at the user end.

5 Bootloading New Firmware

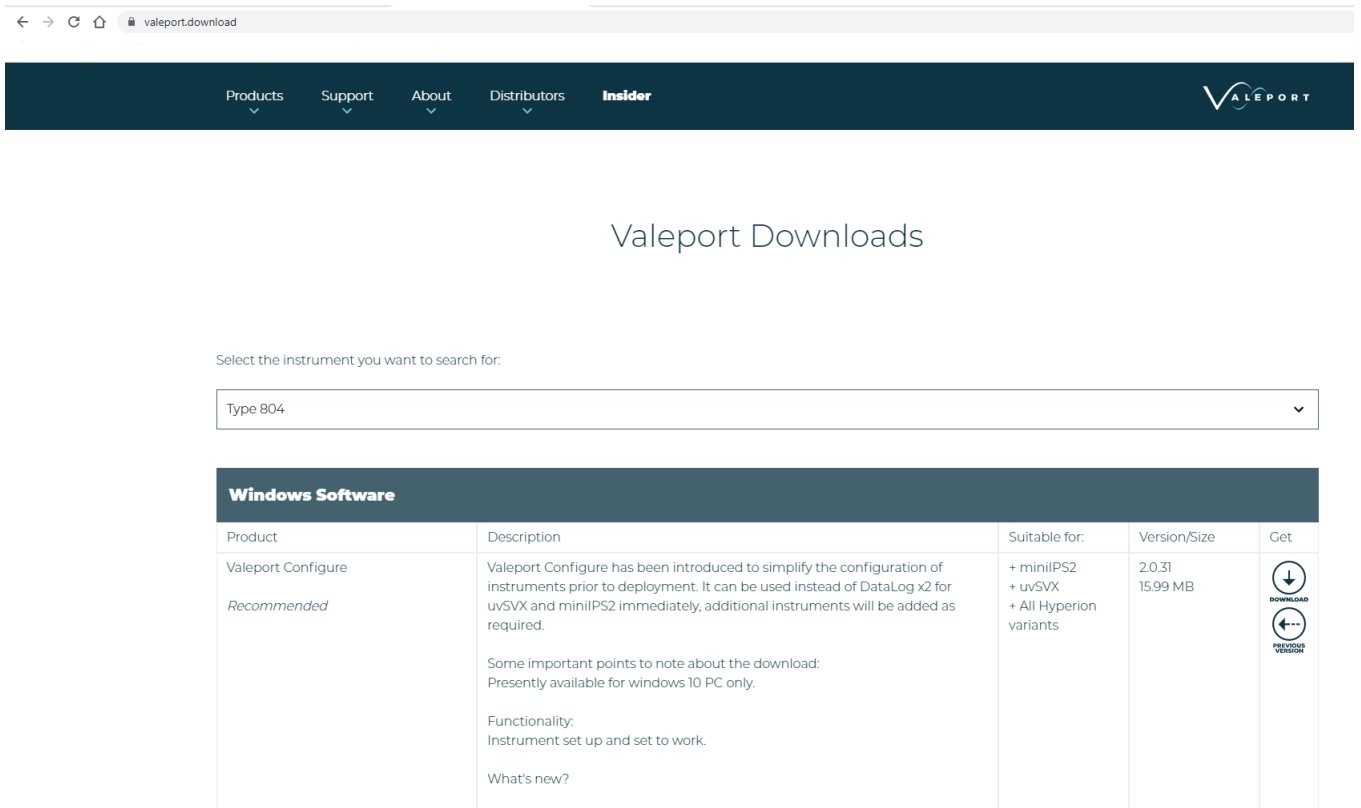
Bootloading firmware into a Type 804 is now achieved using the Valeport Bootloader App available from <http://valeport.download>:



The screenshot shows the Valeport website's 'Downloads' page. At the top, there is a navigation bar with links for Products, Support, About, Distributors, and Insider. The main heading is 'Valeport Downloads'. Below this, a search prompt asks to 'Select the instrument you want to search for:' with a dropdown menu currently set to 'Type 804'. The main content area is titled 'Windows Software' and contains a table with the following data:

Product	Description	Suitable for:	Version/Size	Get
Valeport Configure <i>Recommended</i>	<p>Valeport Configure has been introduced to simplify the configuration of instruments prior to deployment. It can be used instead of DataLog x2 for uvSVX and miniIP52 immediately, additional instruments will be added as required.</p> <p>Some important points to note about the download: Presently available for windows 10 PC only.</p> <p>Functionality: Instrument set up and set to work.</p> <p>What's new?</p>	+ miniIP52 + uvSVX + All Hyperion variants	2.0.31 15.99 MB	 DOWNLOAD  PREVIOUS VERSION

See separate operating manual – Valeport Bootloader App, available from the Valeport and Valeport Water Websites.

6 Output Format Serial COMs

The serial output string follows the format described below. Most parameters are dependent on one setting or another so the output string may vary greatly in length depending on configuration. For configuration please refer the Configure App.

SERIAL OUTPUT > Output Options

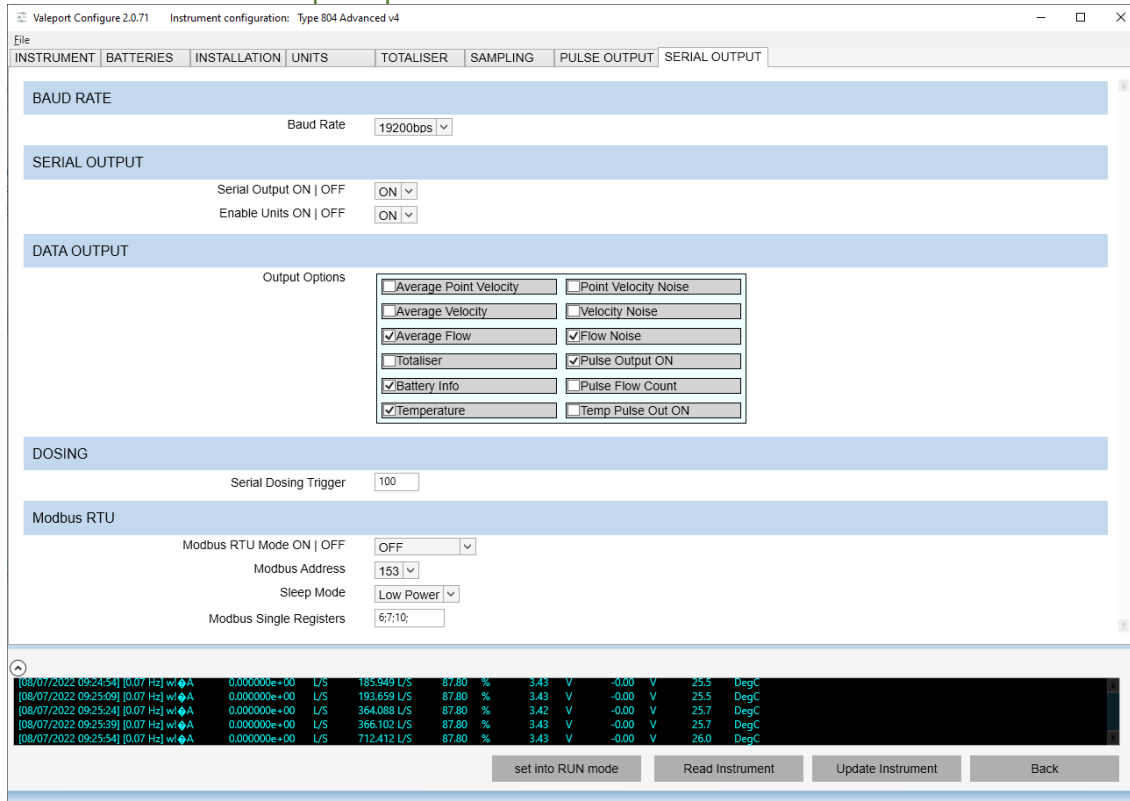

The serial string, seen in the terminal window across the bottom of the app, is made up of a standard set of fields followed by those selected in the form shown above:

```
[Wakeup][BINARY1][BINARY2][BINARY3][WATER][tab][VPAV][tab] [VPAVunits][tab] [SPV][tab]
[SPVunits][tab] [VMAV][tab][VMAVunits][tab] [SMV][tab][SMVunits][tab] [FAV][tab] [FAVunits][tab]
[SVF][tab] [SVFunits][tab][TOT+][tab][TOTunits][tab] [TOT-][tab][TOTunits][tab]
[TOTnet][tab][TOTunits][tab][bat 1][bat 2][bat 3][bat 4][PULSES][tab][TEMPERATURE][tab]
[TEMPERATUREunits][tab][CRLF]
```

Pulse Output ON must be selected for a Pulse output to be enabled regardless of whether a serial output is required or not

Pulse Output ON can also be selected in the PULSE OUTPUT tab

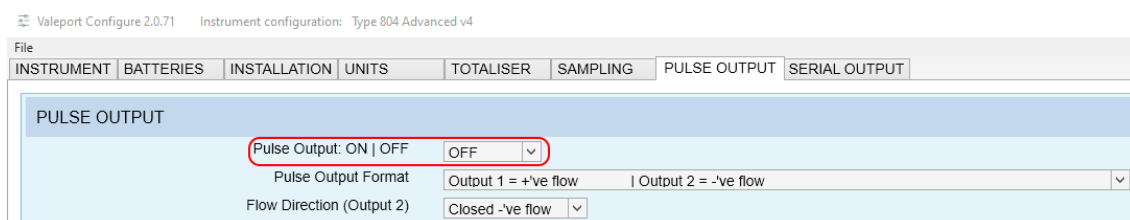

Parameter	Description	Output	Dependency
Wakeup	Wakeup character Followed by a 130mS delay	Single character: 'W' Single character: 'w'	none
BINARY 1	2 bytes output format denoting the parameters being transmitted	2 bytes VPAV 0x0001 SPV 0x0002 VMAV 0x0004 SMV 0x0008 FAV 0x0010 SVF 0x0020 TODD 0x0040 FOUD 0x0080 BATT 0x0100 PULSE COUNT 0x0200 not used 0x0400 not used 0x0800 not used 0x1000	Various see below
	2 bytes alarm output denoting which alarms are set	2 bytes COIL_FAULT 0x0002 BATT1_TYPE_804 0x0004 BATT1_TYPE_804_V 0x0008 EXT_TYPE_804_V 0x0010 VOLUME_REACHED 0x2000	

Parameter	Description	Output	Dependency
BINARY2	2 byte short used by the display units which need to know the cycle time for their flow rate calculations	2 bytes	Pulse Count bit 9 of Output Options
Configure App: SERIAL OUTPUT > Output Options > <input checked="" type="checkbox"/> / <input type="checkbox"/> Pulse Flow Count			

Parameter	Description	Output	Dependency
BINARY3	2 byte short Type 804 self-test alarms	2 bytes not used 0x0001 Out of Water 0x0002 Coil_Fault 0x0004 not used 0x0008 not used 0x0010 not used 0x0020	none

Parameter	Description	Output	Dependency
WATER	Water Detect E – sensor in water, A – sensor in Air	Single character 'E' or 'A'	none

See [Appendix B](#) for details on computation

Parameter	Description	Output	Dependency
VPAV	Average Point Velocity in scientific notation Averaged point velocity over sampling period	“x.xxxxxxe+xx”	optional bit 0 of Output Options
Configure App: SERIAL OUTPUT > Output Options > <input checked="" type="checkbox"/> / <input type="checkbox"/> Average Point Velocity			
VPAV units	ASCII units string of Point Velocity units	“velocity units/time units” e.g. “mm/S”	if output units enabled
Configure App: SERIAL OUTPUT > Enable Units ON OFF			

Parameter	Description	Output	Dependency
VMAV	Average Velocity in scientific notation Uses Blockage factor	“x.xxxxxxe+xx”	optional bit 1 of Output Options
Configure App: SERIAL OUTPUT > Output Options > <input checked="" type="checkbox"/> / <input type="checkbox"/> Average Velocity			
VMAV units	ASCII units string of Average Velocity	“velocity units/time units” e.g. “mm/S”	if output units enabled
Configure App: SERIAL OUTPUT > Enable Units ON OFF			

Parameter	Description	Output	Dependency
FAV	Average Flow in scientific notation	“x.xxxxxxe+xx”	optional bit 2 of Output Options
Configure App: SERIAL OUTPUT > Output Options > <input checked="" type="checkbox"/> / <input type="checkbox"/> Average Flow			
FAV units	ASCII units string of Average Flow	“volume units/volume time units” e.g. “L/S”	if output units enabled
Configure App: SERIAL OUTPUT > Enable Units ON OFF			

Parameter	Description	Output	Dependency
SPV	Point Velocity Noise in scientific notation	“x.xxxxxxe+xx”	optional bit 3 of Output Options
Configure App: OUTPUT > OUTPUT > Output Options > <input checked="" type="checkbox"/> / <input type="checkbox"/> Point Velocity Noise			
SPV units	ASCII units string of Point Velocity	“velocity units/time units” e.g. “mm/S”	if output units enabled
Configure App: SERIAL OUTPUT > Enable Units ON OFF			

Parameter	Description	Output	Dependency
SMV	Average Velocity Noise in scientific notation	“x.xxxxxxe+xx”	optional bit 4 of Output Options
Configure App: SERIAL OUTPUT > Output Options > <input checked="" type="checkbox"/> / <input type="checkbox"/> Velocity Noise			
SMV units	ASCII units string of	“velocity units/time units” e.g. “mm/S”	if output units enabled
Configure App: SERIAL OUTPUT > Enable Units ON OFF			

Parameter	Description	Output	Dependency
SVF	Average Flow Noise scientific notation	"x.xxxxxxe+xx"	optional bit 5 of Output Options
Configure App: SERIAL OUTPUT > Output Options > <input checked="" type="checkbox"/> / <input type="checkbox"/> Flow Noise			
SVF units	ASCII units string is in	"volume units/volume time units" e.g. "L/S"	if output units enabled
Configure App: SERIAL OUTPUT > Enable Units ON OFF			

Parameter	Description	Output	Dependency
TOT+	Total positive Flow scientific notation	"x.xxxxxxe+xx"	optional bit 6 of Output Options
TOT-	Total negative Flow scientific notation	"x.xxxxxxe+xx"	optional bit 6 of Output Options
TOTnet	Total Net Flow scientific notation	"x.xxxxxxe+xx"	optional bit 6 of Output Options
Configure App: SERIAL OUTPUT > Output Options > <input checked="" type="checkbox"/> / <input type="checkbox"/> Totalisers All 3 Totalisers are included			
TOT units	ASCII units string "Totaliser units"	"AAAAA" e.g "M^3"	if output units enabled
Configure App: SERIAL OUTPUT > Enable Units ON OFF			

Parameter	Description	Output	Dependency
FOUT	Pulse Output ON Must be enabled for Flow Pulse output		optional bit 7 of Output Options
Configure App: SERIAL OUTPUT > Output Options > <input checked="" type="checkbox"/> / <input type="checkbox"/> Pulse Output ON			
See Section 6.1			

When the Battery option is selected **SERIAL OUTPUT > Output Options > Battery** the information output will depend upon the Internal Battery Status setting configured in the **BATTERIES** tab of the Configure App:

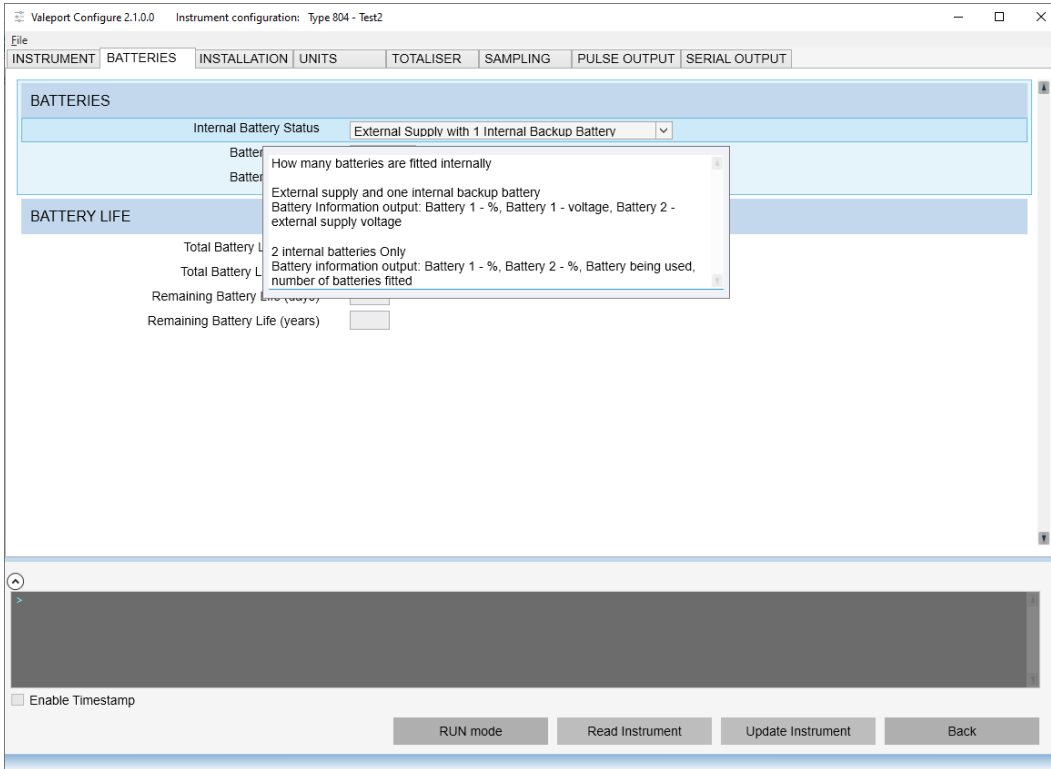

With the Battery Output Option selected:

Set to 1 for: Battery 1 %, Battery 1 voltage, Battery 2 (external) voltage

Set to 2 for: Battery 1 %, Battery 2 %, Battery being used, number of batteries fitted

Parameter	Description	Output	Dependency
bat1	Battery 1 Percentage remaining	"xxx.xx %\t"	optional bit 8 of Output Options
Configure App: SERIAL OUTPUT > Output Options > <input checked="" type="checkbox"/> Battery			

Parameter	Description	Output	Dependency
bat2	Battery 2 Percentage remaining	"xxx.xx %\t"	When #357;1 & optional bit 8 of Output Options(#086)
	Configure App: SERIAL OUTPUT > Output Options > <input checked="" type="checkbox"/> Battery INSTRUMENT > BATTERIES > Internal Battery Status > 2 Internal Batteries		
	Battery 1 Voltage	"x.xx V\t"	optional bit 8 of Output Options
Configure App: SERIAL OUTPUT > Output Options > <input checked="" type="checkbox"/> Battery INSTRUMENT > BATTERIES > Internal Battery Status > External Supply with 1 Internal Backup Battery			
Parameter	Description	Output	Dependency
bat3	Battery Number being used	"x/"	optional bit 8 of Output Options
	Configure App: SERIAL OUTPUT > Output Options > <input checked="" type="checkbox"/> Battery INSTRUMENT > BATTERIES > Internal Battery Status > 2 Internal Batteries		
	Battery 2 Voltage	"x.xx V\t"	optional bit 8 of Output Options

Configure App: SERIAL OUTPUT > Output Options > Battery BATTERIES > Internal Battery Status > 1

Parameter	Description	Output	Dependency
bat4	Battery Number fitted	"x\t"	optional bit 8 of Output Options
Configure App: SERIAL OUTPUT > Output Options > <input checked="" type="checkbox"/> Battery INSTRUMENT > BATTERIES > Internal Battery Status > 2 Internal Batteries			

Parameter	Description	Output	Dependency
PULSE COUNT	Total number of pulses output on the pulse output. This is either the Flow pulses or the Dose pulses NOT Temperature pulses. Set the Pulse Output Type first	"xxxxx"	optional bit 9 of Output Options
Configure App: SERIAL OUTPUT > Output Options > <input checked="" type="checkbox"/> / <input type="checkbox"/> Pulse Flow Count			

Parameter	Description	Output	Dependency
TEMP	Measured water temperature	"xx.x"	optional bit 13 of Output Options
Configure App: SERIAL OUTPUT > Output Options > <input checked="" type="checkbox"/> / <input type="checkbox"/> Water Temperature			
TEMP units	Temperature units	"DegC" or "DegF"	optional bit 13 of Output Options if output units enabled
Configure App: SERIAL OUTPUT > Output Options > Enable Units ON OFF			
Configure App: UNITS > UNITS > Temperature Units			

Parameter	Description	Output	Dependency
FTOUT	Frequency (Temp) Must be enabled for Temperature Pulse output		optional bit 15 of Output Options
Configure App: SERIAL OUTPUT > Output Options > <input checked="" type="checkbox"/> / <input type="checkbox"/> Temp Pulse Output			
See Section 6.1			

Example:

wA 0.000000e-41 mm/S 0.000 mm/S 0.000000e-37 mm/S 0.000 mm/S 0.000000e-37 L/S 0.000 L/S 0.000000e+00 L 0.000000e+00 L 0.000000e+00 L 100.00 % 3.34 V -0.00 V 0 23.0 DegC

6.1 Non - Output Parameters

The following parameters are not output in the serial string but must be enabled to output Pulse telemetry.

PARAMETER	Decimal	HEX	DESCRIPTION
FOUT	128	0x0080	Frequency output for Flow or Dosing. This bit needs to be enabled to be able to generate the total number of pulses in the output string and as physical pulses.
FTOUT	32768	0x8000	Frequency output for Temperature. This bit needs to be enabled to generate physical pulses.

6.2 Alarm Output

Binary 1 alarms - Checks for the alarms are performed on every measurement.

ALARMS	HEX	FUNCTION
COIL_FAULT	0x0002	Measured every reading Coil current is checked to be within a valid range. If the measurement is out of bounds the alarm condition will be set
BATT1_TYPE_804	0x0004	If the capacity drops below the set limit an alarm is sent in the output string
BATT1_TYPE_804_V	0x0008	If the voltage drops below the set limit an alarm is sent in the output string
EXT_TYPE_804_V	0x0010	If the voltage drops below the set limit an alarm is sent in the output string
VOLUME_REACHED	0x2000	As every dose limit is reached an alarm is output on the string output. The flow exceeding the dose limit is retained in the dose limit counter and gets added onto the next consecutive volume reading. e.g. If dose limit is set to 200L and the volume measured in every reading is 80L, then an alarm is sent on the 3rd string output (as the totaliser is 240L). Excess of 40L is added onto the 80L volume measured on the 4th string output

6.3 Supported Units

Velocity	
Units	Return Characters
Millimetre	mm
Metre	M
Feet	Ft

Time	
Units	Return Characters
Second	S
Minute	M
Hour	H
Day	D

Volume/Totaliser	
Units	Return Characters
Litres	L
Mega litres	MGL
Cubic metre	M ³
Gallon	IGL
US Gallon	UGL
Mega-Gallon	MG
Mega-US Gallon	MUG
Feet cube	Ft ³
Kilo Feet cube	KFt ³
Kilo Gallon	KIGL
Kilo US Gallon	KUGL
Kilo Cubic metre	KM ³

Frequency/Pulse Output	
Units	Return Characters
Litres	L
Mega litres	MGL
Cubic metre	M ³
Gallon	IGL
US Gallon	UGL
Mega-Gallon	MG
Mega-US Gallon	MUG
Feet cube	Ft ³

7 Insertion and Profile Factors

The Insertion and Profile factors compensate for the flow characteristics of the pipe and insertion probes presence in the flow. Multiplied together they form the Blocking Factor for the pipe.

7.1 When Using Centre Line Method [sensor positioned in the centre of pipe]

The Profile Factor, F_p is determined from the following graph which has the following curve fit equation:

$$F_p = 6.5039E-18D^5 - 4.2038E-14D^4 + 1.0578E-10D^3 - 1.3251E-07D^2 + 9.1842E-05D + 8.357E-01$$

For example. If $D=200\text{mm}$, $F_p= 0.850$

where D = the internal diameter of the pipe.

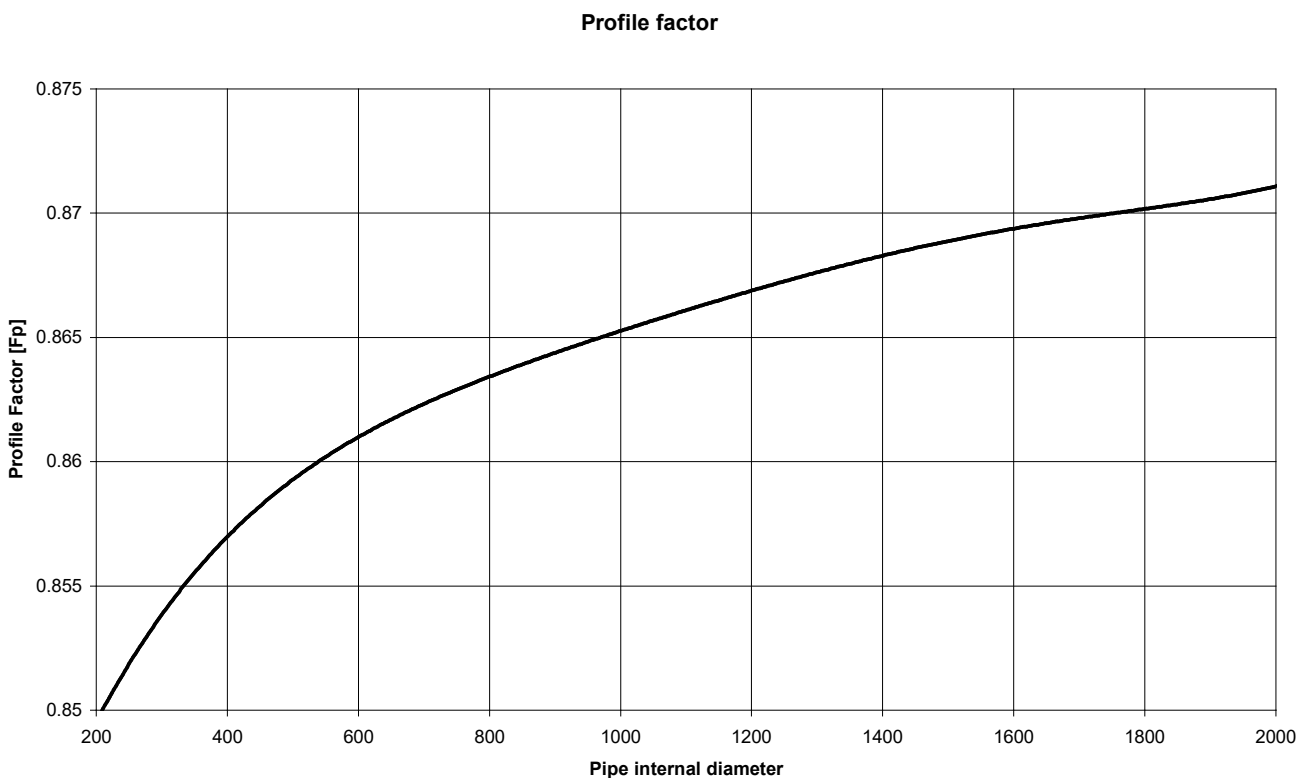

The Insertion Factor, F_i is determined from the following equation:

$$F_i = \frac{1}{\left(1 - \left(\frac{38}{\pi * D}\right)\right)}$$

Where D is the pipe internal diameter in millimetres

For example if $D=200\text{mm}$, the $F_i = 1.064$

7.2 When Using Mean Axial Method [sensor positioned at 1/8th or 7/8th of Pipe Diameter]

The Profile Factor, $F_p = 1$

If the sensor is at 1/8th diameter, then the Insertion Factor $[F_i] = 1 + (12.09/D) + (1.3042/(\sqrt{D}))$

Example, if $D=1000\text{mm}$, $F_{i1/8} = 1.053$

If the sensor is at 7/8th diameter, then the Insertion Factor $[F_i] = 1 + (12.09/D) - (1.3042/(\sqrt{D}))$

Example, if $D=1000\text{mm}$, $F_{i7/8} = 0.971$

7.3 Setting the Insertion and Profile Factors

The Insertion and Profile Factors are set using the Configure App:

[INSTALLATION > INSERTION | PROFILE FACTORS](#)

The factors can be input manually or calculated for you – remember to use the **Update Instrument** button at the bottom of the screen to upload newly calculated or manually programmed factors into the instrument.

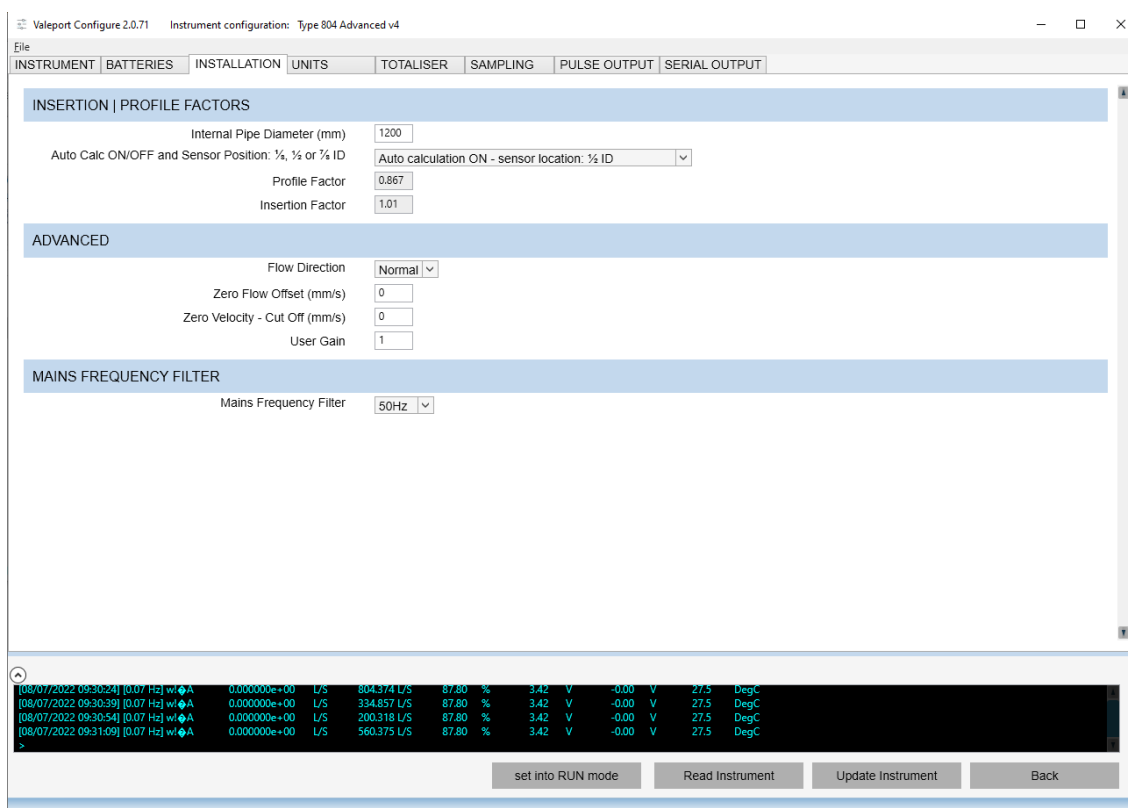

8 Pulse Outputs

Two contact closure outputs are available on all Type 804 instruments. Different functionality is permitted on each of these outputs depending on the requirement of the installation. The options for different outputs are listed below:

Option	Output 1	Output 2
0	Flow Value	Direction
1	Positive Flow	Negative Flow
2	Positive Flow	Temperature
3	Positive Dose	Negative Dose
4		
5	Dose Positive or Dose Negative	Contact: Open for Positive Dose Closed for Negative Dose

Set the Pulse Output Format using the Configure App:

PULSE OUTPUT > Pulse Output Configuration > Pulse Output Format

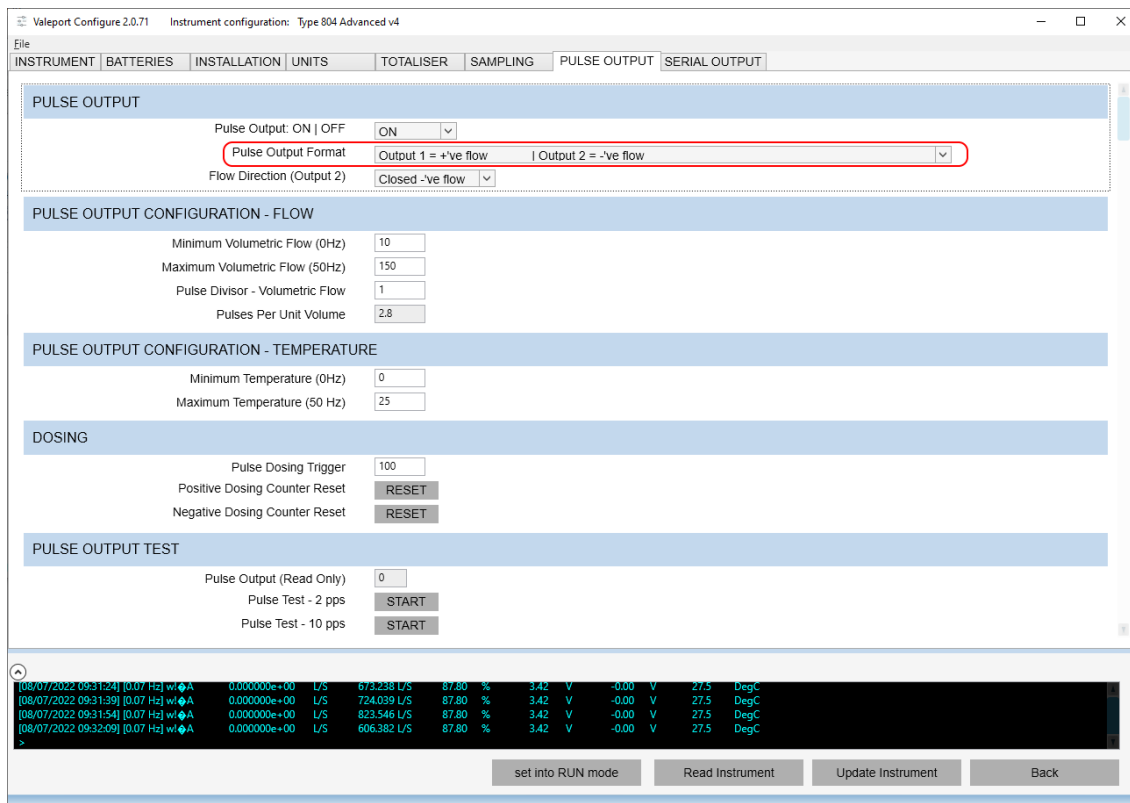

If the instrument is interrupted any Pulse Output stops

8.1 Pulse Output - Flow

For the purpose of this manual and associated software Flow will be considered volumetric flow in selected Pulse Output Units and selected Instrument Volume | Time units over the Measurement Cycle Period.

Depending on the flow calculated and the settings programmed in the instrument the pulse flow output will be continuous and at a fixed frequency for the Measurement Cycle Period after which a new observation is made and flow calculated. The Frequency will be determined based on the Volumetric Flow settings and the Measurement Cycle Period – see examples below.

Between observation and calculation processes the processor goes to sleep to save energy.

After a calculated sleep period the processor wakes up and provides the flow data to the pulse generator and commences a flow observation.

The pulse generator will then transmit the correct number of pulses to represents the total flow volume for the previous Measurement Cycle Period.

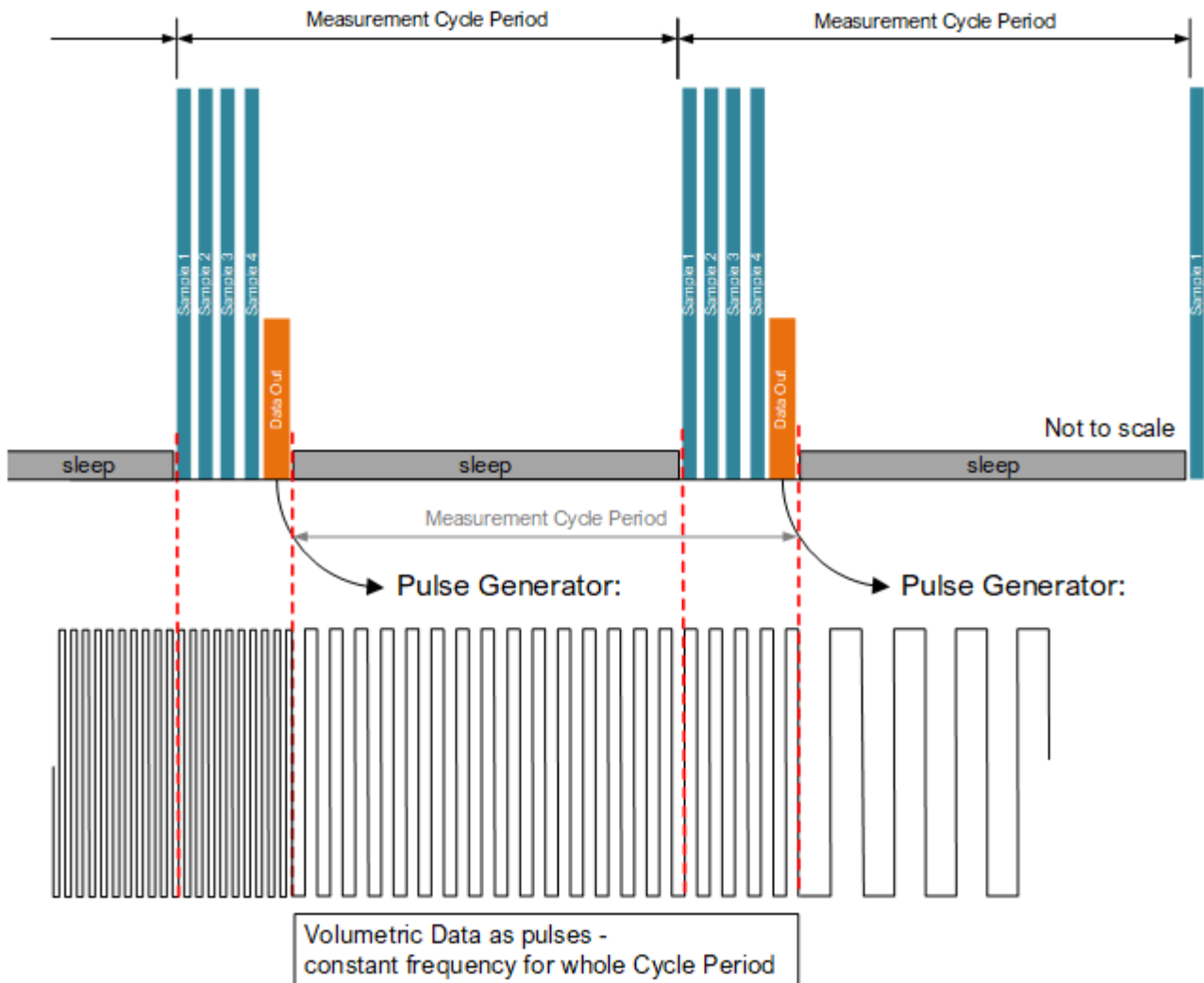

Look at the Pulse frequency from the 3 Measurement Cycle Periods in the diagram above - the flow is slowing down.

note: Totaliser data is broadcast in the Measurement Cycle following that in which it was calculated.

Example

1. **measured flow velocity = 10 litres/second**
2. min volumetric flow for 0Hz output = 0 litres/second
3. max volumetric flow for 50Hz output = 20 litres/second
 (pulses per unit volume = 20(l) / 50(Hz) = 0.4)
4. Measurement Cycle Period = 20 seconds
5. Total Flow in cycle period = 20(s) x 10(l/s) = 200 litres
 200 / 0.4 = 500 pulses or 25Hz

Too many pulses, what are my options?

1. use the Pulse Divisor e.g.:
 set Pulse Divisor to 2: output will be 500 / 2 = 250 pulses or 12.5Hz
2. increase the maximum volumetric flow parameter
 - 2.1. **measured flow velocity = 10 litres/second**
 - 2.2. min volumetric flow for 0Hz output = 0 litres/second
 - 2.3. max volumetric flow for 50Hz output = **50** litres/second
 (pulse factor = 50 (l) / 50(Hz) = 1)
 - 2.4. Measurement Cycle Period = 20 seconds
 - 2.5. Total Flow in cycle period = 20(s) x 10(l) = 200 litres
 200 / 1 = 200 pulses or 10Hz

PULSE OUTPUT > PULSE OUTPUT CONFIGURATION - FLOW>

Minimum Volumetric Flow (0Hz)

Maximum Volumetric Flow (50Hz)

- The pulse per unit volume is calculated for you

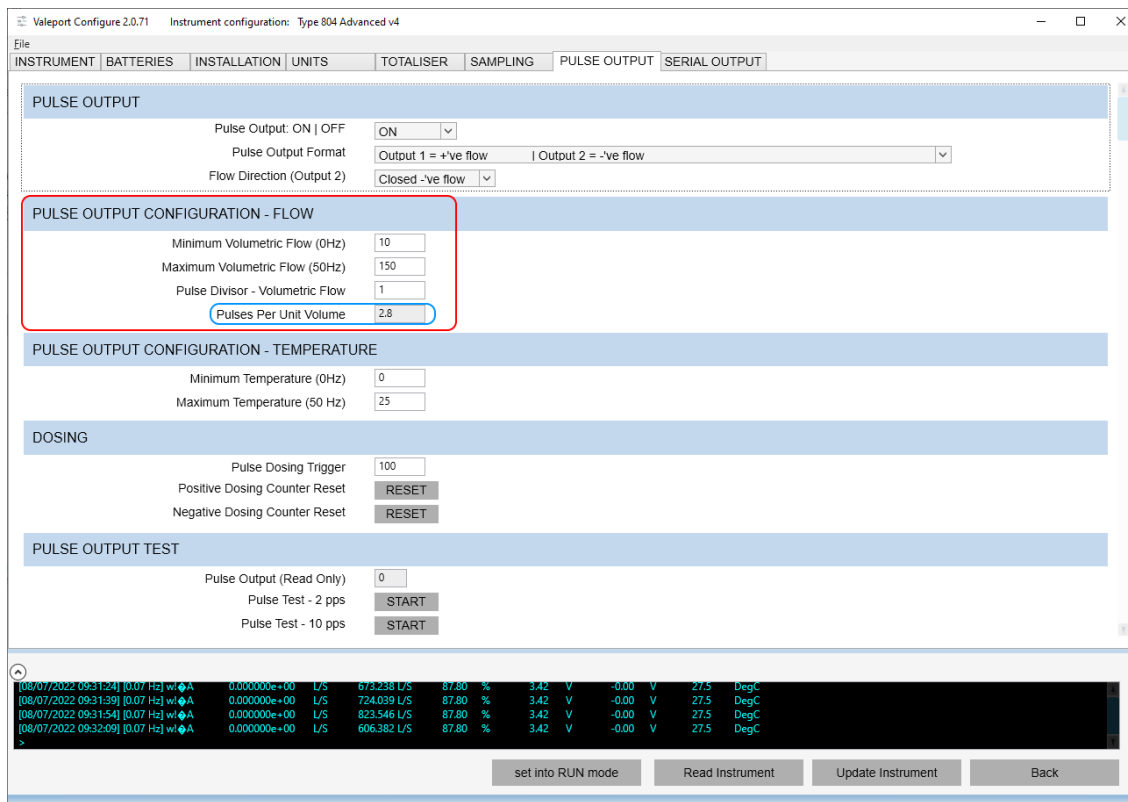

Follow a similar process if you intend to monitor Temperature in

PULSE OUTPUT CONFIGURATION – TEMPERATURE

8.2 Pulse Divisor

The Pulse Divisor is a factor that is used as a fine adjustment of the pulse output range. A Pulse Divisor of 2 will result in half the number of pulses for the same flow rate.

This factor has no effect on the Temperature Pulse Output.

[PULSE OUTPUT > PULSE OUTPUT CONFIGURATION - FLOW>](#)

8.3 Temperature

Depending on the frequency limits a measured temperature will produce a fixed frequency output for a complete cycle time until a new reading is taken. The value of the frequency is set by the temperature relating to D.C. and the temperature relating to the maximum 50Hz output e.g. if the limits are set to 0° and 50° C a temperature of 15° C will result in a 15Hz output.

[PULSE OUTPUT > PULSE OUTPUT CONFIGURATION - TEMPERATURE>](#)

[Minimum Temperature \(0Hz\)](#)

[Maximum Temperature \(50Hz\)](#)

Bit 13 of Output Options is enabled to transmit the temperature reading in the string output but frequency output is not dependant on this setting.

[SERIAL OUTPUT > Output Options > Temperature](#)

8.4 Dosing

Dosing is available to trigger an external device every set volume of flow. For example, if dose limit is set to 10 litres, every 10 litres of flow results in a 50mS pulse. This is updated at measurement time and is not a set frequency. The number of dose pulses is limited to fit within a cycle period plus some processing overhead. If the required number of doses calculated as a result of flow is greater the time available the number of pulses will be limited to a maximum allowable number of pulses. In order to help calculate the instrument settings the time to generate N pulse is given by the formula below:

$$\text{Maximum number of Pulses} = \text{Cycle time} / 0.1034$$

The screenshot shows the 'Valeport Configure 2.0.71' software interface for 'Type 804 Advanced v4'. The 'PULSE OUTPUT' tab is selected. The 'DOSING' section is highlighted with a red box and contains the following settings:

- Pulse Dosing Trigger: 100
- Positive Dosing Counter Reset: RESET
- Negative Dosing Counter Reset: RESET

Other visible sections include:

- PULSE OUTPUT:** Pulse Output: ON | OFF (ON selected); Pulse Output Format: Output 1 = +ve flow | Output 2 = -ve flow; Flow Direction (Output 2): Closed -ve flow
- PULSE OUTPUT CONFIGURATION - FLOW:** Minimum Volumetric Flow (0Hz): 10; Maximum Volumetric Flow (50Hz): 150; Pulse Divisor - Volumetric Flow: 1; Pulses Per Unit Volume: 2.8
- PULSE OUTPUT CONFIGURATION - TEMPERATURE:** Minimum Temperature (0Hz): 0; Maximum Temperature (50 Hz): 25
- PULSE OUTPUT TEST:** Pulse Output (Read Only): 0; Pulse Test - 2 pps: START; Pulse Test - 10 pps: START

At the bottom, there is a data log table and control buttons: 'set into RUN mode', 'Read Instrument', 'Update Instrument', and 'Back'.

Time	Flow	Temp	Pressure	Flow Error	Flow %	Voltage	Current	Temp
[08/07/2022 09:31:24]	0.000000e+00 L/S	673.238 L/S	87.80 %	3.42 V	-0.00 V	27.5 DegC		
[08/07/2022 09:31:39]	0.000000e+00 L/S	724.039 L/S	87.80 %	3.42 V	-0.00 V	27.5 DegC		
[08/07/2022 09:31:54]	0.000000e+00 L/S	823.546 L/S	87.80 %	3.42 V	-0.00 V	27.5 DegC		
[08/07/2022 09:32:09]	0.000000e+00 L/S	606.382 L/S	87.80 %	3.42 V	-0.00 V	27.5 DegC		

Note

The dosing alarm is also available on the serial output string, but only if a Dosing format is selected for the Pulse Output Format.

DOSING

Serial Dosing Trigger: 100

Modbus RTU

Modbus RTU Mode: Modbus Single

Set the trigger value for the dosing alarm
At each consecutive trigger point an alarm is generated
Dosing must be selected for the Pulse Output Format for this to operate

Any flow volume exceeding the Dosing Trigger is retained in the dosing counter then added to the next consecutive volume reading
e.g. If the Dosing Trigger is set to 200L and the flow volume measured at every cycle is 80L, then an alarm is sent on the 3rd cycle (the totaliser is 240L). The excess of 40L is added to the 80L volume measured on the 4th cycle

[08/07/2022 09:38:09] [0.07 Hz] w/A	0.000000e+00	L/S	438.674 L/S	87.80 %	3.42 V	-0.00 V	26.7 DegC
[08/07/2022 09:38:24] [0.07 Hz] w/A	0.000000e+00	L/S	830.714 L/S	87.80 %	3.42 V	-0.00 V	26.7 DegC
[08/07/2022 09:38:39] [0.07 Hz] w/A	0.000000e+00	L/S	536.074 L/S	87.80 %	3.42 V	-0.00 V	26.5 DegC
[08/07/2022 09:38:54] [0.07 Hz] w/A	0.000000e+00	L/S	187.699 L/S	87.80 %	3.42 V	-0.00 V	26.5 DegC

Buttons: set into RUN mode, Read Instrument, Update Instrument, Back

9 Measurement

A flow measurement is controlled using the following setting:

1. Measurement Cycle Period in seconds
2. Number of Samples

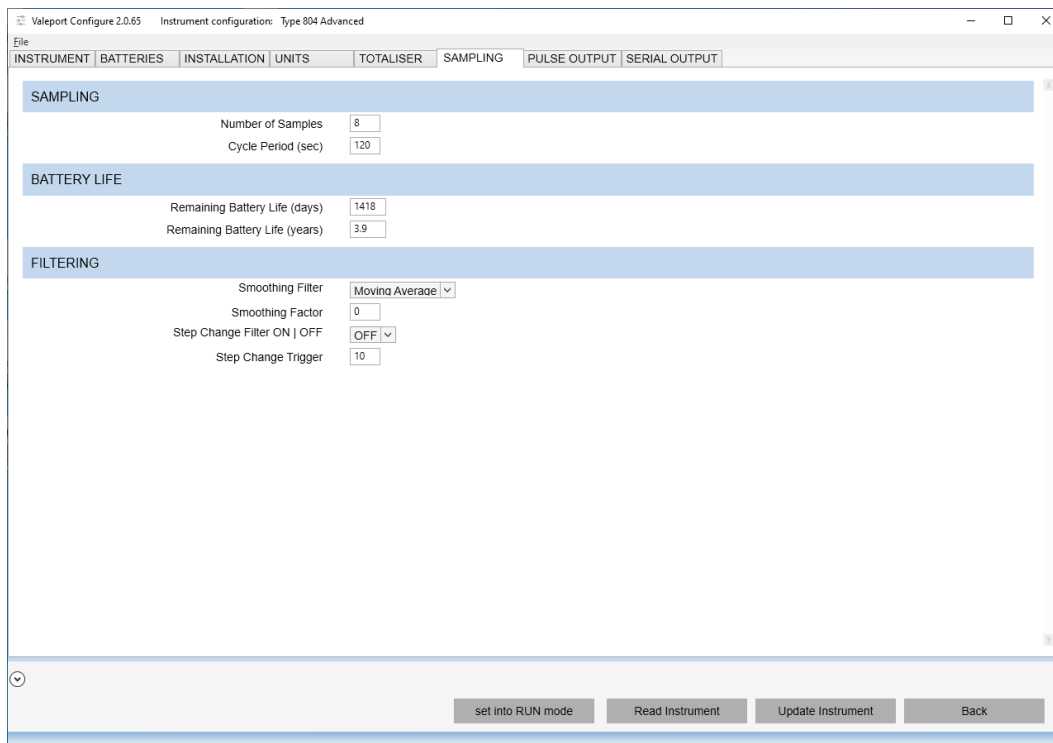

Measurement Cycle Period and Number of Samples are set using in the Configure App. They a major effect on the battery life of the system. For this reason the battery calculations are repeated on the Tab. A major contributor to a short battery life is the Modbus Sleep Mode configured on the SERIAL OUTPUT tab - set to Low Power unless Quick Wake is absolutely required.

A Flow Measurement is calculated every Measurement Cycle Period.

A cycle period of less than 15 seconds prevents the water detect measurement from taking place. The water detect process is performed before each flow measurement. This detection process takes an amount of time that prevents very short Cycle Periods.

A Flow Measurement is made up from a number of sample measurement at a fixed Sampling Frequency rate.

10 Filtering

There are two optional filters available for smoothing the measurements. These are fixed moving average or Exponential smoothing. There is also a step change filter that can be applied to either the Moving Average or Exponential filter

10.1 Moving Average

The average of the last 'n' readings is output as the flow, providing a smoothed output.

10.2 Exponential

The Exponential filter smooths the measurements exponentially with a time constant of 'n' seconds.

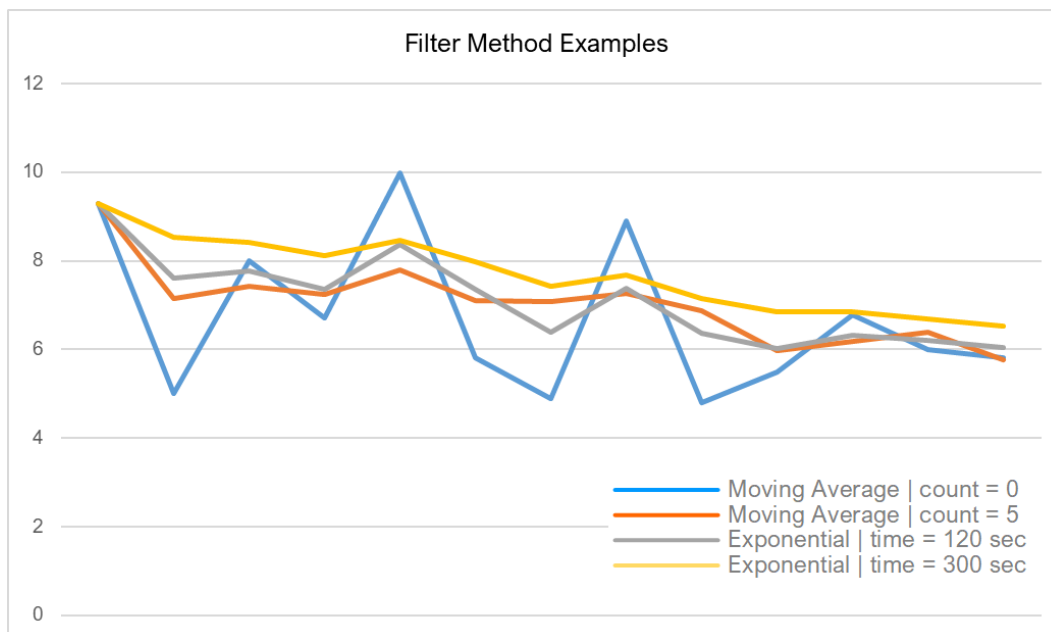

10.3 Step Change

There is a step change function which allows the reset of either filter if the flow increases over a set limit. This allows a step change to be seen immediately rather than wait for the time constant to pass.

11 Battery Measurements

Battery levels for the Type 804 are calculated based on known typical current consumption of the instrument. When a new battery is fitted it is, therefore, important to inform the instrument so that the calculations can be accurately updated.

Please note that if a partially used battery is removed and then refitted, the system no longer knows what capacity is remaining. In this instance the capacity is initially set to 0% when removed. When refitted the system then assumes a capacity of 100% as it has no other information about the battery except that it is fitted. The two battery voltages are then checked and the battery with the lowest voltage is selected.

There are two control codes which inform which battery is new and reset its associated counter.

Battery switching is such that on power up the system selects which battery has the lowest voltage and runs on this battery until it is flat before switching over to the second battery.

The exception to this is if an external battery has been selected option 1

INSTRUMENT > BATTERIES > Internal Battery Status

In this case the instrument will run on battery 2 unless it is flat or removed.

If external supply is reconnected after removal, then the RESET commands should be sent (to reset the battery capacity counter) to clear all the error flags

INSTRUMENT > BATTERIES > New Battery 1 or 2

There are two pieces of information about each battery available. The Battery voltage and its capacity remaining. This information is used for alarms flags.

The Type 804 will operate with whichever battery has the lowest voltage. Once this battery is exhausted it will switch to the second if it is present. When an external supply is available then this will inevitably have a higher voltage and be used in favour of the internal standby battery.

12 Totalisers

There are three totalisers which are constantly updated. These can be set for various units depending on the customer’s requirements. There is a POSITIVE totaliser which increments for positive flow only. There is a NEGATIVE totaliser which increments on negative flow only. There is also a NET totaliser which counts up and down depending on the flow direction.

The totalisers also have the functionality to operate like a mechanical barrel counter where the numbers roll over to zero. This also rolls backwards to a high number (9999) depending on the numbers of digits selected if there is net negative flow.

Advanced User:
 There are actually two sets of totalisers, only the Configurable User Units totaliser are shown Configure Software.
 There are the native totalisers in Litres as well as totalisers in the user units.
 If you require access to both totalisers please contact Valeport Water for details.
 If the rollover function is turned on both types of totalisers will rollover depending on the number of rollover digits selected

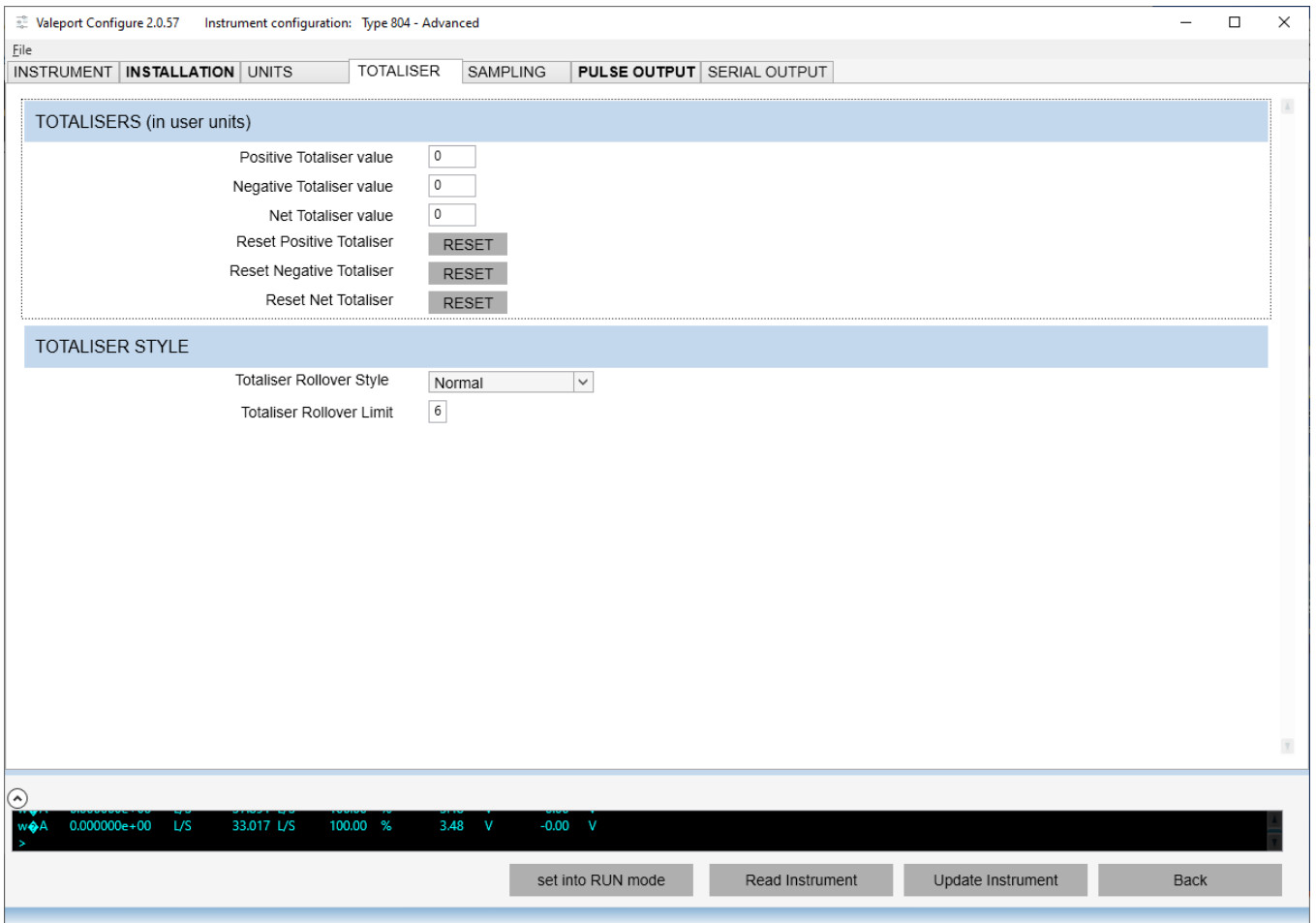

13 Temperature

Temperature of the sensing element can be measured in the Type 804 if enabled. The temperature is measured by a pre-calibrated sensing device. There is no calibration available. Set the minimum and maximum temperatures for 0 and 50 Hz pulse

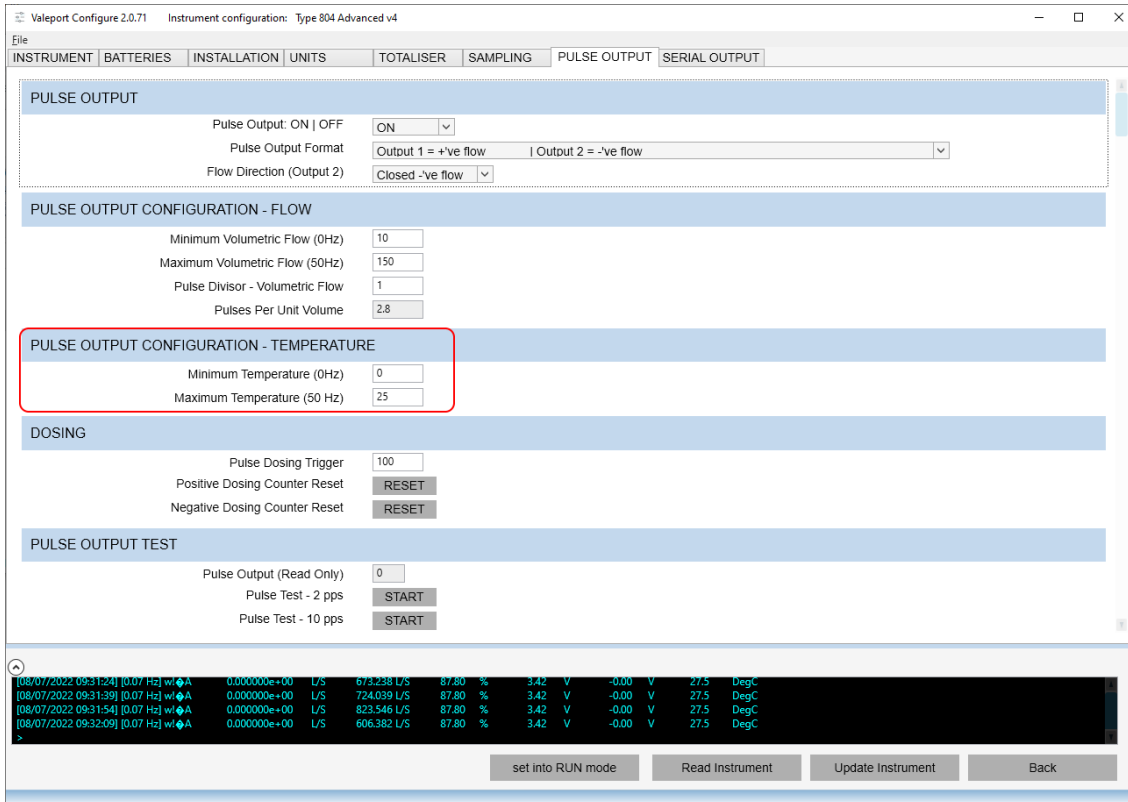

Select Temperature in the Output Options to switch on the output – both Pulse and Serial.

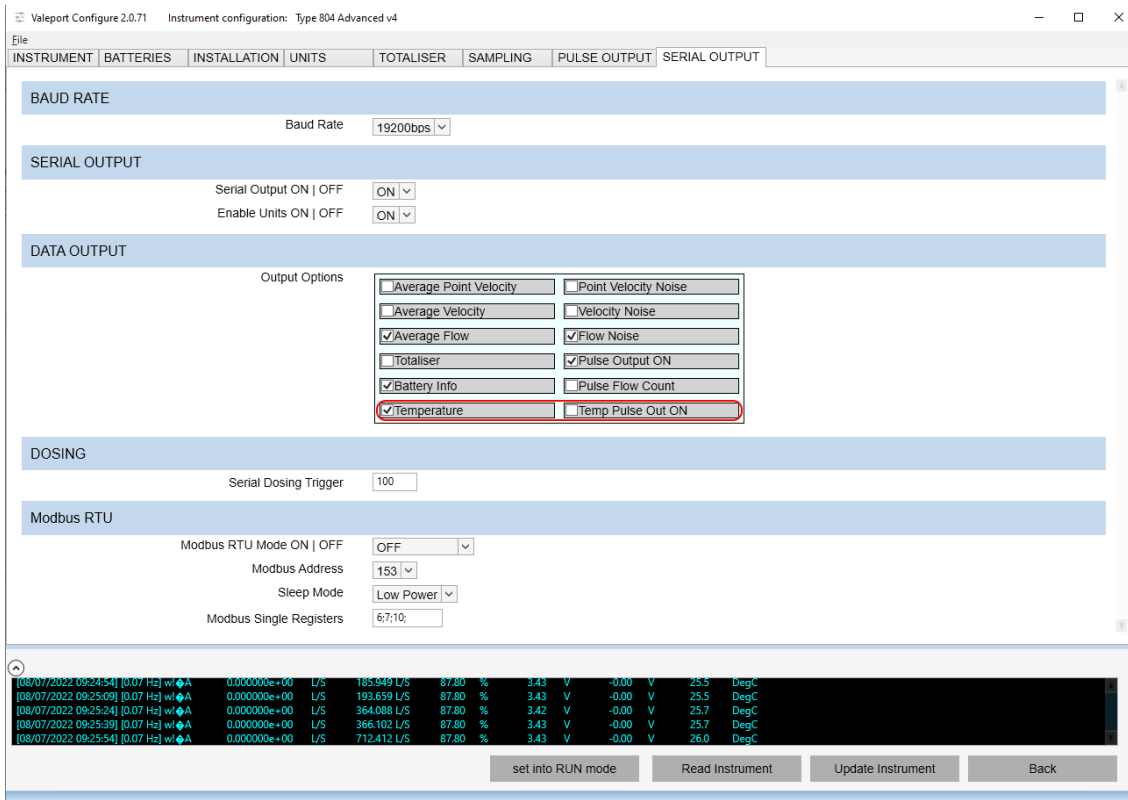

14 Modbus RTU Description

Modbus RTU can be used over RS232 and RS485; the protocol allows the user to configure and operate the Type 804. The Baud rate is variable 4800 to 19200 with 8N1 or 8E1 framing. This conforms to the minimum requirements of the MODBUS standard of 9600 and 19200 baud with 8E1 framing.

Use the Configure App to set it up:

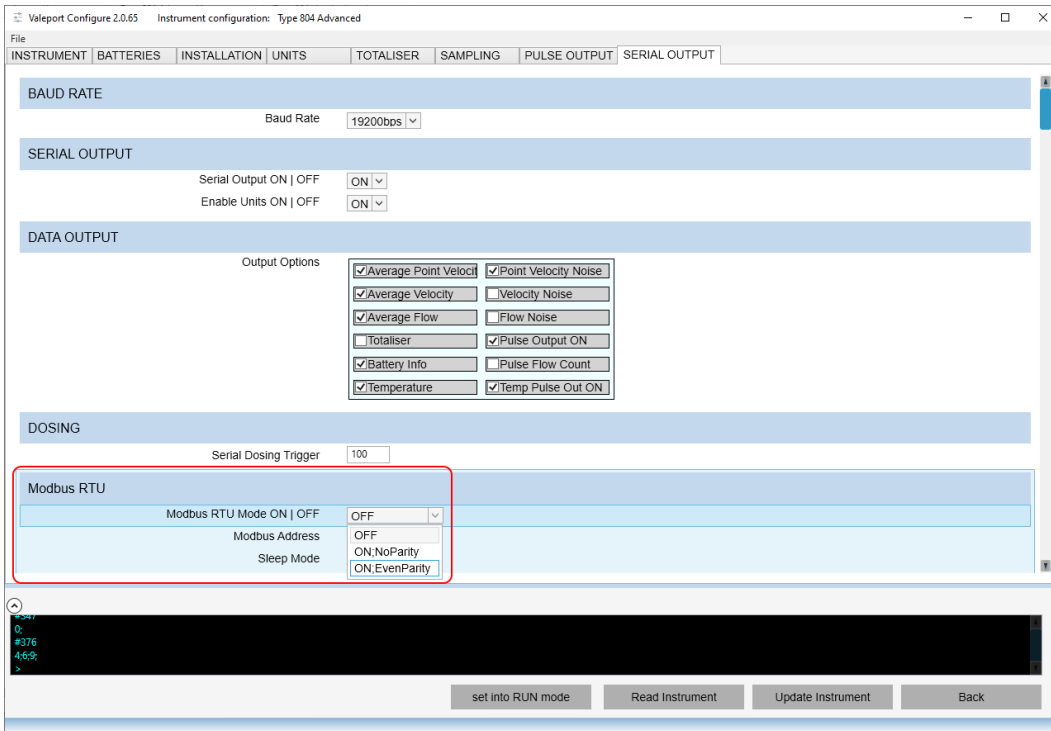

14.1 Delimiting

In Modbus RTU, bytes are sent consecutively with no space between them with 3-1/2 character space between commands for a delimiter, this allows the Type 804 to know when a new command is starting. Any delay between bytes will cause Modbus RTU to interpret it as the start of a new command.

14.2 Format and Byte Size

Each byte is sent as a string of 8 binary characters framed with 1 start bit, even parity or no parity, and 1 stop bit. The framing conforms to both the required standard of 8E1 and the Type 804 standard of 8N1. Making each byte 10 or 11 bits depending on the parity setting.



14.2.1 Slave Address (ID)

The slave ID has to have a value between 1 and 247. (Type 804 default 1 = 0A hex)
 (The Modbus protocol requires that the address 0 is not used, as well as the addresses 248 to 255).
 There is an option (#352) to allow a '#' to interrupt the Type 804 even if in Modbus mode

If this mode is enabled you cannot use an address of 0x23 which is the '#' character.

14.2.2 Function Code

There are two function codes used by the Type 804
 03: The Function Code (Read Holding Registers)
 10: The Function Code (Write Multiple Registers 16 = 10 hex)

14.2.3 Data

The range of data bytes in Modbus RTU can be any characters from 00 to FF (Hex).
 1 Register = 2 Bytes. (Big Endian)

14.2.4 Error Checksum

Each Modbus Command is terminated with two error checking bytes called CRC or Cyclic Redundancy Check.

14.3 Modbus Commands to the Type 804

Type 804 uses two types of Modbus command, one to read a register and other to write to a register. The structure of these two commands are slightly different.

14.3.1 Modbus Command Structure

The example below shows how to read and write to the "text1" field. Typical information that the user might want to store here is site information e.g. location 'MAIN STREET'
 Note that all commands follow the same format and methodology.

Variable Details						
Variable Name		Type	Count	Format		default
survey_info		ASCII	30	N/A		www.valeport.co.uk
Modbus Address	Hash Code	R/W	Access	Low Limit	High Limit	Notes
0021	#004	Read	USER	NUL (00 hex)	DEL (7F hex)	See ASCII Type
	#003	Write	USER			
text1 is up to 30 characters (ASCII Format Type is 1 less than count, NUL terminated)						

14.3.2 Functions

14.3.2.1 Read Holding Registers (FC=03)

Request

→ 05 03 00 84 00 0F 44 63

05: The Slave Address (05 = 05 hex)

03: The Function Code (read Holding Registers)

0084: The Data Address of the first register requested.

000F: The total number of registers requested. (read 15 registers, 30 ASCII characters)

4463: The CRC (cyclic redundancy check) for error checking.

Response

← 05 03 1E 4D 41 49 4E 20 53 54 52 45 45 54 00 00 00 00 00 00 00 00 00 00 00 00 4B 00 00 00 00 00 00 00 00 00 00 00 00 00 00 C7 7E

05: The Slave Address (05 = 05 hex)

03: The Function Code (read Analog Output Holding Registers)

1E: The number of data bytes to follow (1E hex = 30 bytes)

4D41: The contents of register (ASCII: M,A)

494E: The contents of register (ASCII: I,N)

2053: The contents of register (ASCII: ,S)

5452: The contents of register (ASCII: T,R)

4545: The contents of register (ASCII: E,E)

5400: The contents of register (ASCII: T,NULL)

0000: The contents of register (ASCII: NULL, NULL)

0000: The contents of register (ASCII: NULL, NULL)

0000: The contents of register (ASCII: NULL, NULL)

004B: The contents of register (ASCII: NULL, K)

0000: The contents of register (ASCII: NULL, NULL)

0000: The contents of register (ASCII: NULL, NULL)

0000: The contents of register (ASCII: NULL, NULL)

0000: The contents of register (ASCII: NULL, NULL)

0000: The contents of register (ASCII: NULL, NULL)

C77E: The CRC (cyclic redundancy check).

14.3.2.2 Write Multiple Registers (FC=16)

Request

→ 05 10 00 84 00 0F 1E 4D 41 49 4E 0A 00 00 00 00 00 00 00 00 00 00 00 00 00 00 00 00 00 00 00 00 00 00 00 00 00 00 00 00 00 00 00 00 00 00 00 00 00 00 00 00 00 00 00 82 A5

05: The Slave Address (05 = 05 hex)

10: The Function Code (Write Multiple Registers 16 = 10 hex)

0084: The Data Address of the first register

000F: The number of registers to write (write to 15)

1E: The number of data bytes to follow (15 registers x 2 bytes each = 30 bytes)

4D41: The contents of register (ASCII: M,A)

494E: The contents of register (ASCII: I,N)

0A00: The value to write to register (ASCII: 'LF' ,NULL)

0000: The value to write to register (ASCII: NULL, NULL)

0000: The value to write to register (ASCII: NULL, NULL)

0000: The value to write to register (ASCII: NULL, NULL)

0000: The value to write to register (ASCII: NULL, NULL)

0000: The value to write to register (ASCII: NULL, NULL)

0000: The value to write to register (ASCII: NULL, NULL)

0000: The value to write to register (ASCII: NULL, NULL)

0000: The value to write to register (ASCII: NULL, NULL)

0000: The value to write to register (ASCII: NULL, NULL)

0000: The value to write to register (ASCII: NULL, NULL)

0000: The value to write to register (ASCII: NULL, NULL)

0000: The value to write to register (ASCII: NULL, NULL)

82A5: The CRC (cyclic redundancy check) for error checking.

The memory is protected after the variable length, so if the length is an odd number the Length +1 byte will NOT be written to memory even though it is required for the Modbus command format.

Response

← 05 10 00 84 00 0F C1 A0

05: The Slave Address (05 = 05 hex)

10: The Function Code (Write Multiple Registers 16 = 10 hex)

0084: The Data Address of the first register

000F: The number of registers written

C1A0: The CRC (cyclic redundancy check) for error checking.

14.4 Modbus Exception Responses

Following a command request there are 5 possible outcomes from the Type 804 (Slave)

1. The request is successfully processed by the instrument and a valid response is sent.
2. The request is successfully sent to the instrument but is not for the correct address. No response is sent.
3. The request is not received by the instrument therefore no response is sent.
4. The request is received by the instrument with a parity or CRC error. The instrument ignores the request and sends no response.
5. The request is received without an error but cannot be processed by the slave for another reason. The instrument replies with an exception response.

In a normal response, the Type 804 echoes the function code. The first sign of an exception response is that the function code is shown in the echo with its highest bit set. All function codes have 0 for their most significant bit. Therefore, setting this bit to 1 is the signal that the Type 804 cannot process the request.

Function Code in Request	Function Code in Exception Response
03 (03 hex)	131 (83 hex)
16 (10 hex)	144 (90 hex)

14.4.1 Typical Exception Response

01 83 02 C0 F1

01: The Slave Address (1 = 01 hex)

81: The Function Code 03 (with the highest bit set)

02: The Exception Code (ILLEGAL DATA ADDRESS)

C0F1: The CRC (cyclic redundancy check).

Exception Code	Name
01 (01 hex)	ILLEGAL FUNCTION
02 (02 hex)	ILLEGAL DATA ADDRESS (will get set if a register is set without the correct password level)
03 (03 hex)	ILLEGAL DATA VALUE

A more detail list of the exception code can be found in the supporting documents for Modbus.

14.5 Sleep Mode - Quick Wake/Low Power

To enable a response from a single Modbus command use the Configure App:
 SERIAL OUTPUT > Modbus RTU > Sleep Mode

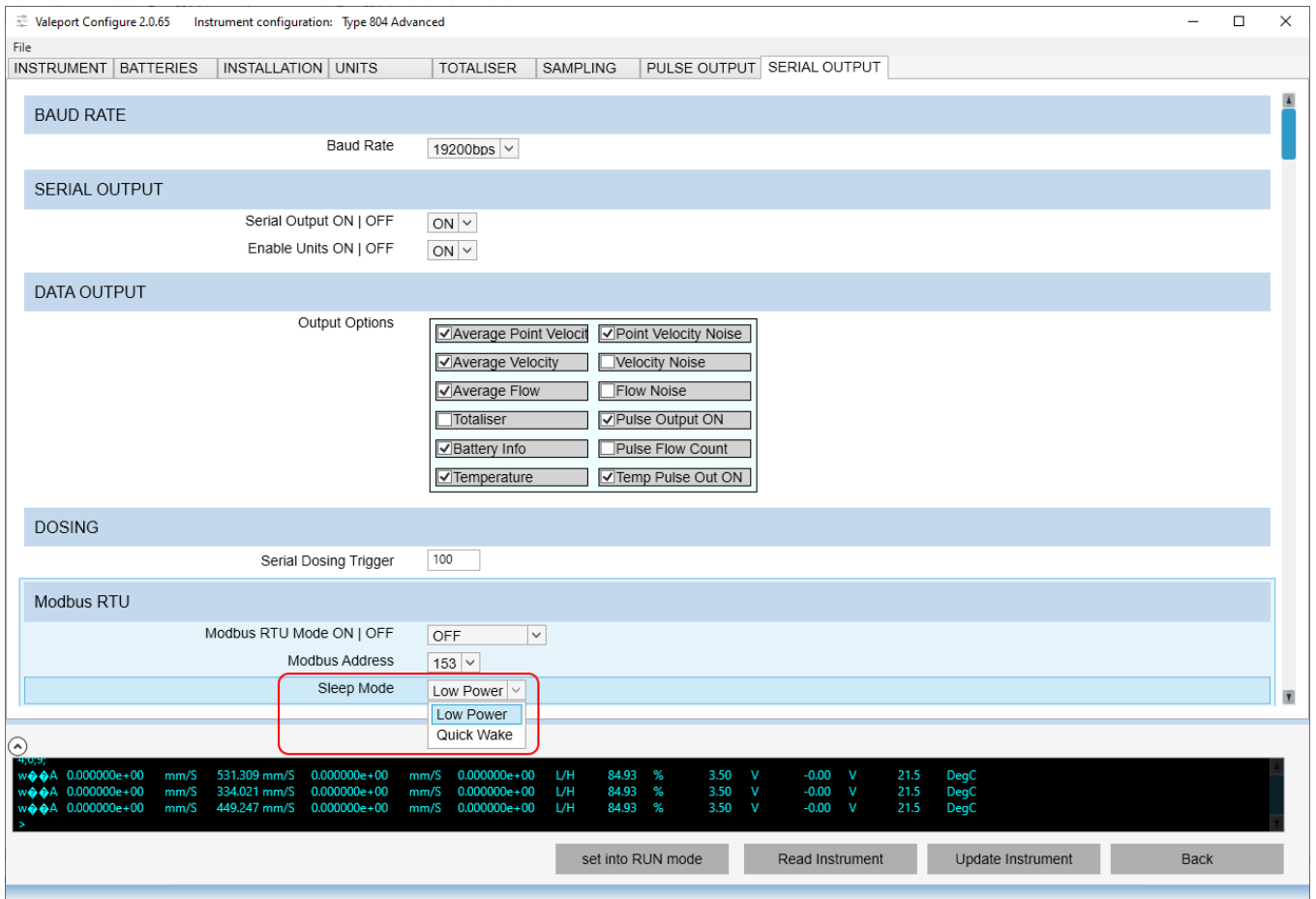

Quick Wake mode will keep the instrument in a raised power state which allows for a quick response to a Modbus command. This setting will have a large impact on the battery life of the Type 804. Use the battery life calculation to assess this.

If this option is not selected you must send a wake character to bring the system out of its lowest power mode before requesting data. Any character can be used but it is advised **not to use the '#' character** as this could also be selected to interrupt the instrument and place it into a configuration mode. After sending the wake character you should send the request after a minimum of 20mS and no later than 490mS from the wake character. The system will wait a further 100mS for any further commands before going back into low power sleep mode. If during the 100mS wait a measurement time occurs the measurement will take priority.

Appendix A # Command and Modbus Register

Code	Followed By	Reply: Echoed Characters Followed By	Operation	Default Value	Data Type	Standard printf Formatting ¹	Min value	Max Value	Access	Modbus Register (Hex)	Number of 2 byte Registers	Reply Timing @ 19200 Baud
#000	;RETAW<CR><LF>	>	Sets password. 'RETAW'	-	F_ASCII	"%c\0",	0	999	USER	0004	4	<100mS
#003	;xxxxxxxx<CR><LF>	>	Set text string 1. e.g. site information 29 characters maximum	'text'	F_ASCII	"%c\0",	0	1	VPW	0021	15	<100mS
#004	<CR><LF>	site information<CR><LF>>	Read text string 1	0	F_ASCII	"%c\0",	0	1	USER	0021	15	<100mS
#005	;xxxxxxxx<CR><LF>	>	Set text string 2. e.g. site information 29 characters maximum		F_ASCII	"%c\0",	0	0	VPW	003F	15	<100mS
#006	<CR><LF>	Calibration<CR><LF>>	Read text string 2	0	F_ASCII	"%c\0",	1200	230400	USER	003F	15	<100mS
#008	;xxxxxxxx<CR><LF>	>	Set text string 3. E.g. site information 29 characters maximum		F_ASCII	"%c\0",	0	1	VPW	005D	15	<100mS
#009	<CR><LF>	Construction<CR><LF>>	Read text string 3	0	F_ASCII	"%c\0",	0	1	USER	005D	15	<100mS
#011	<CR><LF>	##;<CR><LF>>	Read instrument serial number	0	F_ULONG	"%1lu\0",	0	1E+10	USER	007B	2	<100mS
#013	<CR><LF>	##;<CR><LF>>	Read PCB serial number		F_ULONG	"%1lu\0",	1	1E+10	USER	007F	2	<100mS
#014	<CR><LF>	0804XXX<CR><LF>	Read the software version	0804XXX	F_ASCII	"%c\0",	0	1	USER	0083	17.5	<100mS
#016	<CR><LF>	serial_number;<CR><LF>>	Read the sensor serial number	12345	F_ULONG	"%1lu\0",	0	999999	USER	0000	2	<100mS
#018	<CR><LF>	300;<CR><LF>>	Read spar length mm	0	F_ULONG	"%1lu\0",	0	5000	USER	00A6	2	<100mS
#019	;19200<CR><LF>	>	Set the baud rate 4800,9600,19200,38400 Error defaults to 19200	19200	F_ULONG	"%1lu\0",	4800	38400	VPW	00AA	2	43mS
#020	<CR><LF>	19200;<CR><LF>>	Read the baud rate.	0	F_ULONG	"%1lu\0",	4800	38400	USER	00AA	2	25mS
#022	<CR><LF>	170726<CR><LF>>	Read calibration date		F_ASCII	"%c\0",	25	100	USER	00AE	3.5	<100mS
#025	;215<CR><LF>	>	Set the pipe internal diameter in mm	215	F_FLOAT	"%0.0f\0",	0	10000	VPW	00B9	2	<100mS
#026	<CR><LF>	215;<CR><LF>>	Read the pipe internal diameter in mm		F_FLOAT	"%0.0f\0",	0	10000	USER	00B9	2	<100mS
#028	<CR><LF>	>	Puts unit into Run Mode		F_UCHAR	"%1d\0",	0	1	USER	00BD	0.5	² Note 2
#030	;1<CR><LF>	>	Set the insertion factor.	1	F_FLOAT	"%0.4f\0",	0	2	VPW	00BE	2	<100mS
#031	<CR><LF>	1;<CR><LF>>	Read the insertion factor.		F_FLOAT	"%0.4f\0",	0	2	USER	00BE	2	<100mS
#032	;1<CR><LF>	>	Set the profile factor.	0.917	F_FLOAT	"%0.4f\0",	0	10	VPW	00C2	2	<100mS
#033	<CR><LF>	1;<CR><LF>>	Read the profile factor.		F_FLOAT	"%0.4f\0",	0	10	USER	00C2	2	<100mS
#034	;50<CR><LF>	>	Set the mains frequency for filtering. Set to 50 or 60Hz.	50	F_USHORT	"%1u\0",	50	60	VPW	00C6	1	<100mS

¹ see <http://www.cplusplus.com/reference/cstdio/printf/>

² 2.92s = Time taken from <CR> of #028 command to end of first string output (all parameters enabled)
240mS = Time taken for each string

Code	Followed By	Reply: Echoed Characters Followed By	Operation	Default Value	Data Type	Standard printf Formatting ¹	Min value	Max Value	Access	Modbus Register (Hex)	Number of 2 byte Registers	Reply Timing @ 19200 Baud
#035	<CR><LF>	50;<CR><LF>>	Read the mains frequency: 50 or 60.	0	F_USHORT	"%1u\0",	50	60	USER	00C6	1	<100mS
#040	;2<CR><LF>	>	Set the number of samples	2	F_USHORT	"%1u\0",	1	255	USER	00CC	1	<100mS
#041	<CR><LF>	2;<CR><LF>>	Read the number of samples	0	F_USHORT	"%1u\0",	1	255	USER	00CC	1	<100mS
#042	;30<CR><LF>	>	Set the Measurement Cycle Period in seconds max 3600 sec	30	F_USHORT	"%1u\0",	15	3600	USER	00CE	1	<100mS
#043	<CR><LF>	30;<CR><LF>>	Read the Cycle Time	0	F_USHORT	"%1u\0",	15	3600	USER	00CE	1	<100mS
#044	;1<CR><LF>	>	Set the Flow Direction 0 Inverts Flow Direction 1 Normal Flow	1	F_USHORT	"%1u\0",	0	1	USER	00D0	1	<100mS
#045	<CR><LF>	1;<CR><LF>>	Read the Flow Direction		F_USHORT	"%1u\0",	0	1	USER	00D0	1	<100mS
#046	;0<CR><LF>	>	Zero Offset in mm/sec +ve value: subtracted from the reading -ve value: added to reading Zero is adjusted before gain is modified	0	F_FLOAT	"%0.1f\0",	-1000	1000	USER	00D2	2	<100mS
#047	<CR><LF>	0;<CR><LF>>	Read user zero trim		F_FLOAT	"%0.1f\0",	-1000	1000	USER	00D2	2	<100mS
#048	;1<CR><LF>	>	Set the gain factor by which the basic flow reading is to be multiplied by after any zero adjustment	1	F_FLOAT	"%0.4f\0",	-100	100	USER	00D6	2	<100mS
#049	<CR><LF>	1;<CR><LF>>	Read user gain factor		F_FLOAT	"%0.4f\0",	-100	100	USER	00D6	2	<100mS
#050	;20<CR><LF>	>	Set the value in mm/sec for the sample average below which flow is taken as zero	20	F_FLOAT	"%0.1f\0",	-1000	1000	USER	00DA	2	<100mS
#051	<CR><LF>	20;<CR><LF>>	Read user flow zero cut off	0	F_FLOAT	"%0.1f\0",	-1000	1000	USER	00DA	2	<100mS
#052	;1<CR><LF>	>	Set the filter type for smoothing measurement; 0 = Exponential 1 = Moving Average	1	F_USHORT	"%1u\0",	0	1	USER	00DE	1	<100mS
#053	<CR><LF>	1;<CR><LF>>	Read filter type	0	F_USHORT	"%1u\0",	0	1	USER	00DE	1	<100mS
#054	;5<CR><LF>	>	Set time constant for the selected filter In Exponential mode , the number is the time constant for smoothing in seconds. In Moving Average , the number is number of readings [samples], which are in the moving average 0 = no smoothing.	5	F_USHORT	"%1u\0",	0	255	USER	00E0	1	<100mS
#055	<CR><LF>	5;<CR><LF>>	Read time constant	0	F_USHORT	"%1u\0",	0	255	USER	00E0	1	<100mS
#058	;0<CR><LF>	>	Set the Velocity Distance units 0 = mm 1 = Metres 2 = Ft	0	F_USHORT	"%1u\0",	0	2	USER	00E4	1	<100mS

Code	Followed By	Reply: Echoed Characters Followed By	Operation	Default Value	Data Type	Standard printf Formatting ₁	Min value	Max Value	Access	Modbus Register (Hex)	Number of 2 byte Registers	Reply Timing @ 19200 Baud
#059	<CR><LF>	0;<CR><LF>>	Read the Velocity Distance units	0	F_USHORT	"%1u\0",	0	2	USER	00E4	1	<100mS
#060	;0<CR><LF>	>	Set the Volume units – serial output 0 = Litres 1 = Megalitres 2 = Cubic Metres 3 = ImpGal 4 = USGal 5 = MG 6 = MUG 7 = Cubic Feet 8 = Kilo Cubic Feet 9 = Kilo ImpGal 10 = Kilo US Gal 11 = Kilo M^3	0	F_USHORT	"%1u\0",	0	11	USER	00E6	1	<100mS
#061	<CR><LF>	0;<CR><LF>>	Read the Volume units	0	F_USHORT	"%1u\0",	0	11	USER	00E6	1	<100mS
#062	;0<CR><LF>	>	Set the Velocity time units – serial output 0 = Seconds 1 = Minutes 2 = Hours 3 = Days	0	F_USHORT	"%1u\0",	0	3	USER	00E8	1	<100mS
#063	<CR><LF>	0;<CR><LF>>	Read the Velocity time units	0	F_USHORT	"%1u\0",	0	3	USER	00E8	1	<100mS
#064	;2<CR><LF>	>	Set the Totaliser Volume units – serial output 0 = Litres 1 = Megalitres 2 = Cubic Metres 3 = Imp Gal 4 = US Gal 5 = MG 6 = MUG 7 = Cubic Feet 8 = Kilo Cubic Feet 9 = Kilo Imp Gal 10 = Kilo US Gal 11 = Kilo Cubic Metres	2	F_USHORT	"%1u\0",	0	11	USER	00EA	1	<100mS
#065	<CR><LF>	2;<CR><LF>>	Read the Totaliser Volume units	0	F_USHORT	"%1u\0",	0	11	USER	00EA	1	<100mS
#066	;2<CR><LF>	>	Set the Volume Time units 0 = Seconds 1 = Minutes 2 = Hours 3 = Days	2	F_USHORT	"%1u\0",	0	3	USER	00EC	1	<100mS
#067	<CR><LF>	2;<CR><LF>>	Read the Volume Time units	0	F_USHORT	"%1u\0",	0	3	USER	00EC	1	<100mS

Code	Followed By	Reply: Echoed Characters Followed By	Operation	Default Value	Data Type	Standard printf Formatting ₁	Min value	Max Value	Access	Modbus Register (Hex)	Number of 2 byte Registers	Reply Timing @ 19200 Baud
#070	;0<CR><LF>	>	Set Pulse Volume units 0 = Litres 1 = Megalitres 2 = Cubic Metres 3 = Imp Gallons 4 = US Gallons 5 = Mega Gallons 6 = Mega US Gallons 7 = Cubic Feet	0	F_USHORT	"%1u\0",	0	7	USER	00EE	1	<100mS
#071	<CR><LF>	0;<CR><LF>>	Read Pulse Volume units	0	F_USHORT	"%1u\0",	0	7	USER	00EE	1	<100mS
#072	;0<CR><LF>	>	Set Pulse output definition: 0 = Output1 = flow value Output2 = direction 1 = Output1 = +’ve flow Output2 = -’ve flow 2 = Output1 = +’ve flow Output2 = Temperature 3 = Output1 = +’ve dose Output2 = -’ve Dosedose 4 = Not used 5 = Output 1 = dose +’ve or -’ve Output 2 - contact open for +’ve dose and closed for -’ve This must be set to enable serial Dosing alarm	0	F_USHORT	"%1u\0",	0	4	USER	00F0	1	14.5mS
#073	<CR><LF>	0;<CR><LF>>	Read Pulse output type	0	F_USHORT	"%1u\0",	0	4	USER	00F0	1	<100mS
#074	;1<CR><LF>	>	Set Pulse Output 2 direction setting 0 = contact closed = +’ve flow 1 = contact closed = -’ve flow	1	F_USHORT	"%1u\0",	0	1	USER	00F2	1	<100mS
#076	;130<CR><LF>	>	Set Volumetric flow rate in chosen “Pulse units” per “time unit” to correspond to maximum Pulse frequency [50 Hz]	130	F_FLOAT	"%0.1f\0",	0.001	1000000	USER	00F4	2	<100mS
#077	<CR><LF>	130;<CR><LF>>	Read Volumetric flow rate in chosen “Pulse units” per “time unit” to correspond to maximum Pulse frequency		F_FLOAT	"%0.1f\0",	0.001	1000000	USER	00F4	2	<100mS
#078	;0<CR><LF>	>	Set Volumetric flow rate in chosen “Pulse units” per “time unit” to correspond to zero Pulse frequency	0	F_FLOAT	"%0.1f\0",	-1000000	1000000	USER	00F8	2	<100mS
#079	<CR><LF>	0;<CR><LF>>	Read minimum Volumetric flow rate in chosen		F_FLOAT	"%0.1f\0",	-1000000	1000000	USER	00F8	2	<100mS
#080	<CR><LF>	0.000000e+00 L 0.000000e+00 L 0.000000e+00 L 100.00% 0.00% 1/2<CR><LF>>	Read the 3 totaliser values, the % used of each battery and which battery is being used		F_UCHAR	"%1d\0",	0	1	USER	00FC	0.5	145mS

Appendix A | # Command and Modbus Register

Code	Followed By	Reply: Echoed Characters Followed By	Operation	Default Value	Data Type	Standard printf Formatting ¹	Min value	Max Value	Access	Modbus Register (Hex)	Number of 2 byte Registers	Reply Timing @ 19200 Baud
#081	;1<CR><LF>	>	#081;1 indicates new Batt 1 is fitted #081;2 indicates new Batt 2 is fitted If both new batteries, repeat this command for each. This command simply reset the % used figure to 100% and reset the counter for the battery to '0'. This counter value is used for the calculation of battery capacity (#412 & #414)	1	F_UCHAR	"%1d\0",	1	2	VPW	00FD	0.5	20mS
#086	;455<CR><LF>	>	Set what parameters are output. single short made up from "OR'ing" the following bits and adding VPAV [0 or 1] x 01d 01h VMAV [0 or 1] x 02 d 02h FAV [0 or 1] x 04 d 04h SPV [0 or 1] x 08 d 08h SMV [0 or 1] x 16 d 10h SVF [0 or 1] x 32 d 20h TOTD [0 or 1] x 64 d 40h FOUT [0 or 1] x 128 d 80h BATT [0 or 1] x 256d 100h PULSE_COUNT [0 or 1] x 512d 200h not used M_ENABLED [0 or 1] x 2048d 800h DEC_ENABLED [0 or 1] x 4096d 1000h WATER_TEMP [0 or 1] x 8192d 2000h not used FTOUT [0 or 1] x 32768d 8000h	455	F_USHORT	"%1u\0",	0	65535	USER	00FE	1	25mS
#087	<CR><LF>	455;<CR><LF>>	Read what parameters are output in the single number format as set	1	F_USHORT	"%1u\0",	0	65535	USER	00FE	1	<100mS
#088	;1<CR><LF>	>	Set units on/off in serial data string 0 = Off 1 = On	1	F_USHORT	"%1u\0",	0	1	USER	0100	1	<100mS
#089	<CR><LF>	1;<CR><LF>>	Read the units on/off flag	1	F_USHORT	"%1u\0",	0	1	USER	0100	1	<100mS
#090	;1<CR><LF>	>	Divisor for Pulse per volume unit output. e.g. 2 = 1/2 number of pulses for the same flow. This factor affects no other output.	1	F_FLOAT	"%0.4f\0",	0.001	1E+10	VPW	0102	2	<100mS
#091	<CR><LF>	1;<CR><LF>>	Read Pulses per volume unit	1	F_FLOAT	"%0.4f\0",	0.001	1E+10	USER	0102	2	<100mS
#110	;10<CR><LF>	>	Step change in mm that will cause the smoothing filters to be reset when option is enabled [#112].	10	F_FLOAT	"%0.0f\0",	0	1000	VPW	01A6	2	<100mS
#111	<CR><LF>	10;<CR><LF>>	Read step change which will cause the smoothing filters to be reset	0	F_FLOAT	"%0.0f\0",	0	1000	USER	01A6	2	<100mS

Code	Followed By	Reply: Echoed Characters Followed By	Operation	Default Value	Data Type	Standard printf Formatting ¹	Min value	Max Value	Access	Modbus Register (Hex)	Number of 2 byte Registers	Reply Timing @ 19200 Baud
#112	;0<CR><LF>	>	Set Step Change filter reset in the smoothing algorithms. 0 = Off 1 = On If enabled, a change of larger than the limit will cause the smoothing filters to be reset resulting in the raw reading rather than a smoothed value.	0	F_UCHAR	"%1d\0",	0	1	VPW	01AA	0.5	<100mS
#113	<CR><LF>	0;<CR><LF>>	Read if smoothing filters can be reset after a step change is exceeded.	0	F_UCHAR	"%1d\0",	0	1	USER	01AA	0.5	<100mS
#140	;1<CR><LF>	>	Serial Output Set the Volume Trigger for Dosing. As each Volume Trigger is reached an alarm is generated on the serial string output and the Dosing Volume Trigger totaliser reset. If there is any volume exceeding the Trigger Volume after an alarm is generated, it is retained in the Dosing Volume Trigger totaliser. e.g. if the Volume Trigger is set to 200L and the volume measured in each cycle is 80L, then an alarm is sent on the 3rd cycle's serial string output (the Dosing Volume Trigger totaliser is 240L). The excess 40L is retained in the Dosing Volume Trigger totaliser to be added to the next cycle's volume reading within the totaliser	1	F_FLOAT	"%0.2f\0",	0	1000000	USER	016F	2	<100mS
#141	<CR><LF>	1;<CR><LF>>	Read the Dosing Volume Trigger	0	F_FLOAT	"%0.2f\0",	0	1000000	USER	016F	2	<100mS
#142	;1<CR><LF>	>	Pulse only Set the Totaliser 'Trigger Volume' for a 50mS Dose Pulse to be set on the Pulse Output. Multiple pulses are generated if multiple Dose trigger occurs within a reading	1	F_FLOAT	"%0.2f\0",	0.1	100	USER	0173	2	<100mS
#143	<CR><LF>	1;<CR><LF>>	read the Totaliser Trigger volume	0	F_FLOAT	"%0.2f\0",	0.5	100	USER	0173	2	<100mS
#216	<CR><LF>	batt1 958 batt2 0 batt1 3.5399V batt2 -0.0047V <CR><LF>	Read Battery Voltage from each input. On exit - revert to the original battery selection. (multiple obs taken - must break out with # cmd)	0	F_UCHAR	"%1d\0",	0	1	USER	017C	0.5	<x?

Code	Followed By	Reply: Echoed Characters Followed By	Operation	Default Value	Data Type	Standard printf Formatting ¹	Min value	Max Value	Access	Modbus Register (Hex)	Number of 2 byte Registers	Reply Timing @ 19200 Baud
#240	<CR><LF>	0;<CR><LF>>	Low power flag if either battery is dead (<2.9V)	0	F_UCHAR	"%1d\0",	0	1	USER	01AB	0.5	<100mS
#241	<CR><LF>	0;<CR><LF>>	Out of water flag. On every reading, the electrode signals are checked to be within a valid range for water conditions	0	F_UCHAR	"%1d\0",	0	1	USER	01AC	0.5	<100mS
#242	<CR><LF>	0;<CR><LF>>	Coil fault flag (on every reading, the coil current is checked to be within a valid range)	0	F_UCHAR	"%1d\0",	0	1	USER	01AD	0.5	<100mS
#244	<CR><LF>	0;<CR><LF>>	Low battery capacity flag for battery 1 and battery 2 if both internal battery	0	F_UCHAR	"%1d\0",	0	1	USER	01AF	0.5	<100mS
#313	;0<CR><LF>	>	Temperature unit 0 = Celsius 1 = Fahrenheit	0	F_UCHAR	"%1d\0",	0	1	USER	01B2	0.5	<100mS
#314	<CR><LF>	0;<CR><LF>>	Read Temperature unit	0	F_UCHAR	"%1d\0",	0	1	USER	01B2	0.5	<100mS
#315	;30<CR><LF>	>	Set Temperature in chosen units to correspond to maximum Pulse frequency [50Hz]	30	F_FLOAT	"%0.1f\0",	-2	40	USER	01B3	2	<100mS
#316	<CR><LF>	30;<CR><LF>>	Read Temperature in chosen units to correspond to maximum Pulse frequency		F_FLOAT	"%0.1f\0",	-2	40	USER	01B3	2	<100mS
#317	;0<CR><LF>	>	Set Temperature in chosen units to correspond to zero Pulse frequency	0	F_FLOAT	"%0.1f\0",	-2	40	USER	01B7	2	<100mS
#318	<CR><LF>	0;<CR><LF>>	Read Temperature in chosen units to correspond to zero Pulse frequency		F_FLOAT	"%0.1f\0",	-2	40	USER	01B7	2	<100mS
#324	<CR><LF>	0<CR><LF>>	Read the specific alarm codes. 0 = Good 1 = Noise level exceeded 2 = Out of water 4 = Coil Fault 64 = Battery dead 128 = Battery low capacity	0	F_UCHAR	"%1d\0",	0	1	USER	01BF	0.5	<100mS
#342	;10<CR><LF>	>	Set the battery capacity limit which denotes a flat Lithium battery	10	F_FLOAT	"%0.4f\0",	1	100	USER	01F1	2	<100mS
#343	<CR><LF>	10<CR><LF>>	Read the battery capacity limit which denotes a flat Lithium battery as a %	3	F_FLOAT	"%0.4f\0",	1	100	USER	01F1	2	<100mS

Code	Followed By	Reply: Echoed Characters Followed By	Operation	Default Value	Data Type	Standard printf Formatting ¹	Min value	Max Value	Access	Modbus Register (Hex)	Number of 2 byte Registers	Reply Timing @ 19200 Baud
#346	;0<CR><LF>	>	Set the sleep type. Low Power 0 = normal low power requires a wake character before sending the request modbus command between 20 and 490mS later 1 = quick wake for modbus reply from a single modbus request	0	F_UCHAR	"%1d\0",	0	1	USER	01F9	0.5	<100mS
#347	<CR><LF>	0<CR><LF>>	Read the sleep type.	0	F_UCHAR	"%1d\0",	0	1	USER	01F9	0.5	<100mS
#348	;0<CR><LF>	>	Set normal or mechanical style totalisers 0 = Normal 1 = Mechanical 0 - 9999 etc. forward and backwards <i>(Note only Net Totaliser will work backwards)</i>	0	F_UCHAR	"%1d\0",	0	1	USER	01FA	0.5	<100mS
#349	<CR><LF>	0<CR><LF>>	Read Totaliser set up	0	F_UCHAR	"%1d\0",	0	1	USER	01FA	0.5	<100mS
#350	;6<CR><LF>	>	Set the number of digits used if the Totalisers are working like a mechanical counter. Max = 8	6	F_UCHAR	"%1d\0",	2	8	USER	01FB	0.5	<100mS
#351	<CR><LF>	6<CR><LF>>	Read the number of digits used if the Totalisers are working like a mechanical counter.	0	F_UCHAR	"%1d\0",	2	8	USER	01FB	0.5	<100mS
#352	;0<CR><LF>	>	Flag to enable using '#' character to leave Modbus mode and enter configure mode using # codes with 8N1 Framing. If using this you cannot use address 0x23 for Modbus.	0	F_UCHAR	"%1d\0",	0	1	USER	01FC	0.5	<100mS
#353	<CR><LF>	0<CR><LF>>	Read Flag to enable using '#' character to leave Modbus mode	0	F_UCHAR	"%1d\0",	0	1	USER	01FC	0.5	<100mS

Code	Followed By	Reply: Echoed Characters Followed By	Operation	Default Value	Data Type	Standard printf Formatting	Min value	Max Value	Access	Modbus Register (Hex)	Number of 2 byte Registers	Reply Timing @ 19200 Baud
#354	<CR><LF>	0.0;0.0;0.0;0.0;0.0;0.0;0.0;0.0;0.0;0.0; <CR><LF>>	Read the current measurement values. Only used for Modbus RTU. Do not use the #code as it will not respond with the correct values. These are the same values you see in the serial output including conversion factors where appropriate. Battery status is NOT available. Measurement array locations #define RAW_FLOW_CAL 0 instantaneous velocity in mm/s #define FLOW_CAL 1 velocity in mm/s after any smoothing #define Vpav 2 average point velocity over sampling period #define Spv 3 noise of point velocity over sampling period #define Vmav 4 average mean velocity over sampling period #define Smv 5 noise of mean velocity over sampling period #define Fav 6 average volumetric flow over sampling period #define SvF 7 noise of volumetric flow over sampling period #define TFav 8 average flow in litres / second #define Temperature 9 Single observation per measurement cycle	0.0;0.0;0.0;0.0; 0.0;0.0;0.0;0.0; 0.0;0.0;	F_FLOAT	"%0.1f\0",	-0.000001	1000000	USER	01FD	20	160mS
#357	;0<CR><LF>	>	This needs to be set if the instrument is to use internal batteries only. If not, it assumes that the internal battery is a backup and will run off of the external, potentially higher capacity, battery. External supply and internal battery backup 2 Internal batteries	0	F_UCHAR	"%1d\0",	0	1	VPW	0226	0.5	<100mS
#358	<CR><LF>	0<CR><LF>>	Read power set up	0	F_UCHAR	"%1d\0",	0	1	USER	0226	0.5	<100mS
#360	;0<CR><LF>	>	Set if the serial data is transmitted. 0= Serial output off i.e. only Pulse output 1 = Serial output on Has no effect in Modbus mode.	0	F_UCHAR	"%1d\0",	0	1	USER	0231	0.5	17mS
#361	<CR><LF>	0<CR><LF>>	Read serial data output status	0	F_UCHAR	"%1d\0",	0	1	USER	0231	0.5	17mS
#372	<CR><LF>	0<CR><LF>>	reading 1 request register to read a single specific data value	0	F_FLOAT		-0.000001	1000000	USER	024A	2	17mS
#373	<CR><LF>	0<CR><LF>>	reading 2 request register to read a single specific data value	0	F_FLOAT		-0.000001	1000000	USER	024E	2	17mS
#374	<CR><LF>	0<CR><LF>>	reading 3 request register to read a single specific data value	0	F_FLOAT		-0.000001	1000000	USER	252	2	17mS

Code	Followed By	Reply: Echoed Characters Followed By	Operation	Default Value	Data Type	Standard printf Formatting	Min value	Max Value	Access	Modbus Register (Hex)	Number of 2 byte Registers	Reply Timing @ 19200 Baud
#375	;0;2;9<CR><LF>	>	<p>Sets the three single output values R1,R2,R3 to the specific value from the measurement parameter array according to the list below.</p> <p>If battery information is required you MUST use this collection method Firmware version 0804719B17 or higher required for battery status data</p> <p>0 RAW_FLOW_CAL instantaneous velocity in mm/s 1 FLOW_CAL velocity in mm/s after any smoothing 2 Vpav average point velocity over sampling period 3 Spv noise of point velocity over sampling period 4 Vmav average mean velocity over sampling period 5 Smv noise of mean velocity over sampling period 6 Fav average volumetric flow over sampling period 7 Svf noise of volumetric flow over sampling period 8 TFav averaged volumetric flow over sampling period in litres 9 Temperature Single observation per measurement cycle 10 Battery1 Voltage Single observation per measurement cycle 11 Battery2 Voltage Single observation per measurement cycle 12 Battery1 Percentage Single observation per measurement cycle 13 Battery2 Percentage Single observation per measurement cycle</p>	0;1;2	F_UCHAR	0	0	13	VPW	0256	1.5	17mS
#376	<CR><LF>	0;2;9<CR><LF>>	Read the three single output values R1;R2;R3	0;1;2	F_UCHAR	0	0	13	USER	0256	1.5	17mS
#392	;0<CR><LF>	>	<p>Sets the insertion depth and auto calculate status</p> <p>0 Insertion depth 1/8 Auto calc Off 1 Insertion depth 1/8 Auto calc On 2 Insertion depth 1/2 Auto calc Off 3 Insertion depth 1/2 Auto calc On 4 Insertion depth 7/8 Auto calc Off 5 Insertion depth 7/8 Auto calc On</p>	0	F_UCHAR	"%1d\0",	0	5	VPW	0265	0.5	17mS
#393	<CR><LF>	0<CR><LF>>	Reads the insertion depth and auto calc status	0	F_UCHAR	"%1d\0",	0	5	USER	0265	0.5	17mS
#400	;0<CR><LF>	>	Set value for Positive Totaliser Used to reset Totaliser	0	F_FLOAT	"%1.0f\0",	0	3E+38	USER	0232	2	17mS
#416	<CR><LF>	0<CR><LF>>	Read Positive Totaliser value	0	F_FLOAT	"%1.0f\0",	0	3E+38	USER	0232	2	17mS
#402	;0<CR><LF>	>	Set value for Negative Totaliser Used to reset Totaliser	0	F_FLOAT	"%1.0f\0",	-3E+38	0	USER	0236	2	17mS
#417	<CR><LF>	0<CR><LF>>	Read Negative Totaliser value	0	F_FLOAT	"%1.0f\0",	-3E+38	0	USER	0236	2	17mS
#404	;0<CR><LF>	>	Set value for Net Totaliser Used to reset Totaliser	0	F_FLOAT	"%1.0f\0",	-3E+38	3E+38	USER	023A	2	17mS

Appendix A | # Command and Modbus Register

Code	Followed By	Reply: Echoed Characters Followed By	Operation	Default Value	Data Type	Standard printf Formatting	Min value	Max Value	Access	Modbus Register (Hex)	Number of 2 byte Registers	Reply Timing @ 19200 Baud
#418	<CR><LF>	0<CR><LF>>	Read the value of the net Totaliser in User Units.	0	F_FLOAT	"%1.0f\0",	-3E+38	3E+38	USER	023A	2	17mS
#408	;0<CR><LF>	>	Pulse Output Internal counter for calculation of +ve dose pulse. Set to Zero at install time.	0	F_FLOAT	"%1.0f\0",	0	65535	USER	0193	2	<100mS
#409	<CR><LF>	0; <CR><LF>	Read internal counter for calculation of +ve dose pulse	0	F_FLOAT	"%1.0f\0",	0	65535	USER	0193	2	<100mS
#410	;0<CR><LF>	>	Internal counter for calculation of -ve dose pulse. Set to Zero at install time.	0	F_FLOAT	"%1.0f\0",	0	65535	USER	0197	2	<100mS
#411	<CR><LF>	0; <CR><LF>	Read internal counter for calculation of -ve dose pulse	0	F_FLOAT	"%1.0f\0",	0	65535	USER	0197	2	<100mS
#700	;ON_OFF;PARITY<CR><LF>	>	Enables Modbus communications mode and if parity is on or off. Once entered into Modbus mode the probe will begin to measure on the measurement cycle. 0;0<CR><LF> = OFF 1;0<CR><LF> = ON; No Parity 1;1<CR><LF> = ON; Even Parity	ON_OFF; PARITY	F_UCHAR	"%1d\0",	0	1	VPW	01E2	1	100mS
#701	<CR><LF>	>	Read Modbus comms status and Parity If # break in to Modbus mode [#352] is active do not use this command to activate Modbus mode. You must use #700	0	F_UCHAR	"%1d\0",	0	1	USER	01E2	1	24mS
#702	;10<CR><LF>	>	Set the Modbus address of Type 804	10	F_UCHAR	"%1d\0",	1	247	VPW	01E4	0.5	<100mS
#703	<CR><LF>	xxx<CR><LF>>	Read the Modbus address of Type 804	0	F_UCHAR	"%1d\0",	1	247	USER	01E4	0.5	<100mS
#888	<CR><LF>	Instrument will reset in 10 seconds.<CR><LF>	Used to reset micro to invoke bootloader	0	F_UCHAR	"%1d\0",	0	1	VPW	01A3	0.5	
#999	<CR><LF>	>	Reset factory defaults.	0	F_UCHAR	"%1d\0",	0	1	USER	0182	0.5	186mS

Appendix B Flow Computations

Vpav = Average Point Velocity	= (FLOW_CAL * time_conversion_factor) / (velocity_conversion_factor);
Spv = Point Velocity Noise	= (std_dev * time_conversion_factor) / (velocity_conversion_factor);
Vmav = Average Velocity	= Vpav * blockage_factor;
Smv = Average Velocity Noise	= Spv * blockage_factor;
Fav = Average Flow	= (FLOW_CAL * blockage_factor * pipe_internal_area * volume_time_conversion_factor) / volume_conversion_factor;
Svf = Average Flow Noise	= (std_dev * blockage_factor * pipe_internal_area * volume_time_conversion_factor) / volume_conversion_factor;
TFav = Average Flow (litres)	= (FLOW_CAL * blockage_factor * pipe_internal_area) / 1000000.0; // Ave flow in litres/second
Pulse =	= (FLOW_CAL * blockage_factor * pipe_internal_area * time_conversion_factor) / pulse_conversion_factor; (Value is set by the flow relating to D.C. and the maximum 50Hz output)
pipe_internal_area	= (PI*pipe_diameter*codes.pipe_diameter)/4;
blockage_factor	= insertion_factor * profile_factor

Basic measurements of flow at the sensor [internal data]			
Parameter	Symbol	How derived	Units
Raw instantaneous point velocity	Rp	From electronics	counts
Calibrated instantaneous point velocity	Cp	Applying hydrodynamic fit, scale factor, zero offset	mm/sec
Averaged point velocity over sampling period	FLOW_RAW_CAL	Numerical mean of the samples over the sampling period	mm/sec
Smoothed point velocity over sampling period	FLOW_CAL	Average point velocity either smoothed exponentially or as a moving average, with user defined time constant/averaging period	mm/sec
Noise of point velocity over sampling period	Std_dev	Standard deviation of the samples over the sampling period	mm/sec

Derived measurements of pipe flow			
Parameter	Symbol	How Derived	Units
User corrected smoothed point velocity	U _{sm}	FLOW_CAL corrected for direction, user offset and user gain	mm/sec
Averaged point velocity over sampling period	V _{pav}	U _{sm} * units	Chosen
Averaged mean velocity over sampling period	V _{mav}	U _{sm} * F _p * F _i * units	Chosen
Averaged volumetric flow over sampling period	F _{av}	U _{sm} * $\pi D^2/4$ * F _p * F _i * units	Chosen
Noise of point velocity over sampling period	S _{pv}	Std_dev * units	Chosen
Noise of mean velocity over sampling period	S _{mv}	Std_dev * F _p * F _i * units	Chosen
Noise of volumetric flow over sampling period	S _{vf}	Std_dev * $\pi D^2/4$ * F _p * F _i * units	Chosen
Totaliser digital. Total +ve Total -ve Total net	TOTd	F _{av} * T * units	Chosen
Pulse output	F _{out}	One full square wave cycle per unit volume. 2 channels. Either +ve/-ve or Value/Direction or +ve flow/Temperature Or Dose outputs	Chosen
	TFAV	Average flow in Litres / second	L/S
Insertion factor	F _i	calculated	
Profile Factor	F _p	calculated	
Cycle Time	T		

time_conversion_factor / volume_time_conversion_factor

Seconds	= 1
Minutes	= 60
Hours	= 3600
Days	= 86400

Velocity_conversion_factor

Mm	= 1
M	= 1000
Ft	= 304.8

volume_conversion_factor / totaliser_units

L	= 1000000.0
MGL(Mega Litres)	= 1000000000000.0
M3	= 1000000000.0
KM3	= 1000000000000.0
IGL	= 4546090.0
KIGL	= 4546090000.0
UGL	= 3785411.784
KUGL	= 3785411784
MG(Mega imperial gallons)	= 4546090000000.0
MUG(Mega US gallons)	= 3785411784000.0
FT3	= 28316846.592
KFT3	= 28316846592.0

Pulse units

L	= 1000000.0
MGL(Mega Litres)	= 1000000000000.0
M3	= 1000000000.0
IGL	= 4546090.0
UGL	= 3785411.784
KUGL	= 3785411784
MG(Mega imperial gallons)	= 4546090000000.0
MUG(Mega US gallons)	= 3785411784000.0
FT3	= 28316846.592

Appendix C Declaration of Conformity UK and EU

Please note: Any changes or modifications to the product or accessories supplied, that are not authorised by Valeport Ltd, could void the CE compliance of the product and negate your authority to operate it. This product has demonstrated CE compliance under conditions that include the use of shielded cables. It is important that you use shielded cables compliant with the product’s conformance, to protect from potential damage and reduce the possibility of interference to other electronic devices

UK Declaration of Conformity

Manufacturer:	Valeport Ltd
Address:	St Peter’s Quay, Totnes, Devon, TQ9 5EW
Certification marking:	UKCA
Product Description:	Type 0804, Type 804 ExP

We the manufacturer declare that the product **Type 804, Type 804 ExP** is in conformity with the following UK Statutory requirements and designated standard(s):

Electromagnetic Compatibility Regulations 2016	Standards
EMC (SI 2016 No.1091)	BS EN 61326-1:2021 (Basic Level)

ROHS Regulations 2012	Standards
SI 2012 No. 3032	BS EN IEC 63000:2018

Name:	Surya Dinesh
Position:	Product Support Manager
Place of issue:	Valeport Ltd, Totnes, UK
Date of issue:	31 March 2022
Signature:	

Valeport Limited
St. Peter’s Quay, Totnes,
Devon TQ9 5EW UK

+44 (0) 1803 869292
sales@valeport.co.uk
www.valeport.co.uk

VAT No: GB 165 8753 67
Registered in England No: 1950444



EU Declaration of Conformity

Manufacturer:	Valeport Ltd
Address:	St Peter's Quay, Totnes, Devon, TQ9 5EW
Certification marking:	CE
Product Description:	Type 804, Type 804 ExP

We the manufacturer declare that the product **Type 804, Type 804 ExP** is in conformity with the following EU Directives and harmonised standard(s):

EMC Directive 2014/30/EU	Standards
EMC (Article 3.1b)	BS EN 61326-1:2021 (Basic Level)

RoHS Directive 2015/863/EU	Standards
Prevention (Article 4.1)	BS EN IEC 63000:2018

Name:	Surya Dinesh
Position:	Product Support Manager
Place of issue:	Valeport Ltd, Totnes, UK
Date of issue:	31 March 2022
Signature:	

Valeport Limited
 St. Peter's Quay, Totnes,
 Devon TQ9 5EW UK

+44 (0) 1803 869292
 sales@valeport.co.uk
 www.valeport.co.uk

VAT No. GB 165 8753 67
 Registered in England No. 1950444

